



## ISUZU MU-X RJ MY25 FACELIFT ON PREDATOR & TORO FRONT BAR

### **IMPORTANT! – READ BEFORE INSTALLATION**

- When installed in accordance with these instructions, the front protection bar does not affect the operation of the vehicle's SRS airbags.
- This product must be installed exactly as per these instructions using only hardware supplied.
- Take a few moments to read instructions thoroughly before beginning work.
- In the event of damage to any bar component please contact OFFROAD ANIMAL to arrange repair/replacement of components.
- Do not use this product for any vehicle make or model other than that specified on these instructions.
- Do not remove labels from this product.
- This product and its fixings must not be modified in any way unless stated in these fitting instructions.
- The installation of this product is recommended for trained personnel.
- These instructions are correct at time of publication. OFFROAD ANIMAL cannot be held responsible for the impact of any changes subsequently made by the vehicle manufacturer. If you find something has changed please contact us to let us know!
- During installation it is the duty of the installer to check correct operation/clearances of all components.
- If Instructions are to be printed for reference in the workshop, it is recommended that they are printed in colour, for best legibility.

## GENERAL CARE AND MAINTENANCE

Use caution when cleaning with pressure washers, as they may compromise the product coating's integrity. Exercise care to avoid surface damage.

Only wash the product with a PH neutral car wash to prevent paint damage and discolouration.

Do not use acidic or alkaline based cleaning products.

Plastic parts may be maintained with silicone spray.

It is important to perform regular checks (pre/during/post trip or on an annual basis) on the installed product. More frequent checks may be required in extreme use cases. Checks include:

- Visual inspection for damage (eg. cracks, chips, dents etc.)
- Electrical wiring is not rubbing anything or worn out
- Bolts are torqued to correct specification (see torque guide below)

For touching up small stone chips, Offroad Animal recommends the following paint products:

- Dupli-Color Trim & Bumper Paint Black (TB101)
- VHT Hood, Bumper & Trim Paint Black (SP27)

## BOLT TORQUE SETTINGS

Use the following bolt torques on all general fasteners, unless otherwise specified.

GENERAL FASTENERS	
Size	Torque Nm
M5	5 Nm
M6	9 Nm
M8	22 Nm
M10	44 Nm
M12	77 Nm

Use the following bolt torques on all structural front bar mount and tow point fasteners, and rear towbar fasteners, unless otherwise specified.



FRONT BAR MOUNTS AND TOW POINTS + REAR TOWBAR	
Size	Torque Nm
M10	57 Nm
M12	100 Nm
M14	164 Nm
M16	248 Nm



**Always use a torque wrench to set correct torque settings. Ensure torque wrench is set to Nm unit of measurement. Otherwise perform conversion to lb-ft.**

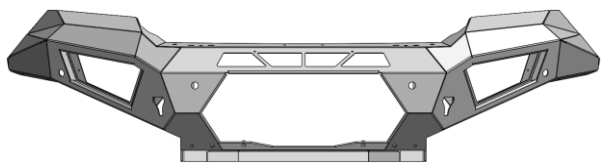
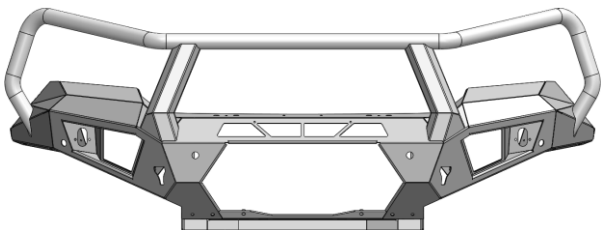

# PARTS LISTING

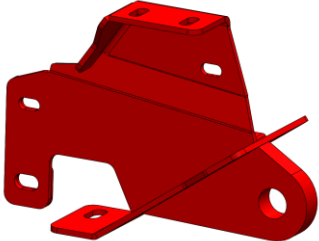

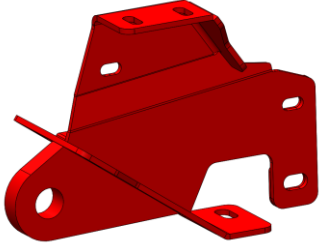
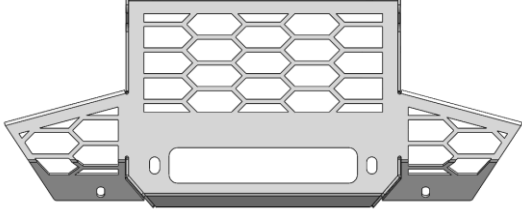
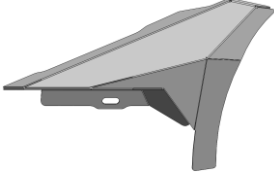
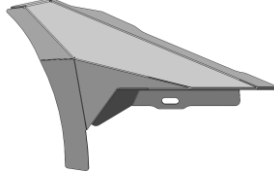
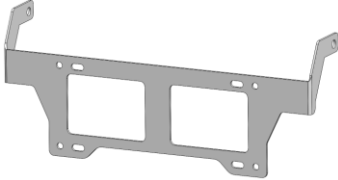
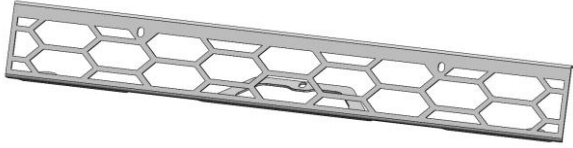

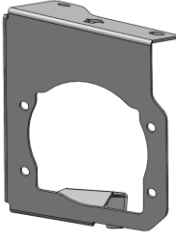

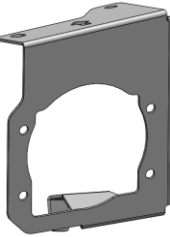
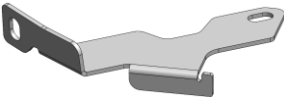
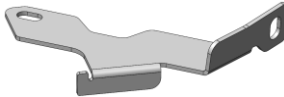
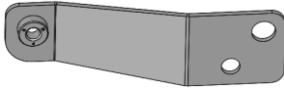
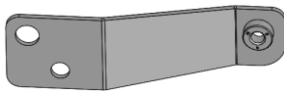
**IMPORTANT:** Check all parts are present before beginning work! Contact OFFROAD ANIMAL if something is missing.

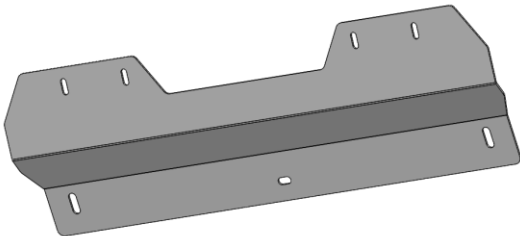
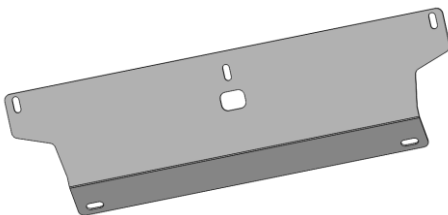
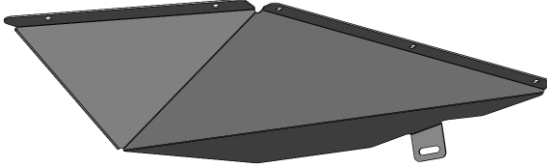
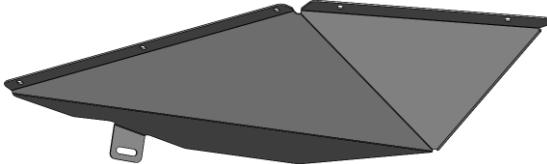
## Main Parts – In the Box

Qty	Part Number	Description	Image
1	FB-IMX-RJ-25-PR-ASM1	Isuzu MU-X MY25 Facelift Predator Bar Welded Assembly	
<b>OR</b>			
1	FB-IMX-RJ-25-TOR-ASM1	Isuzu MU-X MY25 Facelift Toro Bar Welded Assembly	
1	FB-MBT-TF-25-PR-ASM2R	BT-50 TF MY25 Facelift Impact Assembly RH	
1	FB-MBT-TF-25-PR-ASM2L	BT-50 TF MY25 Facelift Impact Assembly LH	
1	FB-IDM-RG-21-PR-ASM3R	ISUZU DMAX 21+ TOW POINT ASSY RH	

1	FB-IDM-RG-21-PR-ASM3L	ISUZU DMAX 21+ TOW POINT ASSY LH	
1	FB-IDM-RG-24-PR-ASM2	D-MAX MY24 Facelift Mesh Fairlead Welded Assembly	
1	FB-IMX-RJ-25-PR-ASM2R	Isuzu MU-X MY25 Facelift Grille Infill Welded Assembly RH	
1	FB-IMX-RJ-25-PR-ASM2L	Isuzu MU-X MY25 Facelift Grille Infill Welded Assembly LH	
1	B-0822	WL Predator Number Plate Bracket	
1	B-1485	22" Lightbar Mesh Infill	
<b>OR</b>			
1	P-0515	22" Lightbar Mesh Infill Plate	
1	B-1581R	MU-X MY25 Facelift Fog Light Bracket RH	

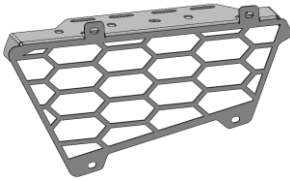
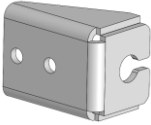
1	B-1581L	MU-X MY25 Facelift Fog Light Bracket LH	
1	B-1584R	MU-X MY25 Facelift Grille Infill Mount RH	
1	B-1584L	MU-X MY25 Facelift Grille Infill Mount LH	
1	B-1585R	MU-X MY25 Facelift Headlight Bracket RH	
1	B-1585L	MU-X MY25 Facelift Headlight Bracket LH	
1	B-1605	Mazda BT-50 MY25 Facelift Pan Brace	
1	U-0036	Isuzu DMAX 2021+ Predator Bash Plate	
1	U-0041	DMAX 21+ Supplementary Underpanel	
1	U-0114R	MU-X MY25 Facelift Side Underpanel RH	
1	U-0114L	MU-X MY25 Facelift Side Underpanel LH	

4	CPHP035	Plastic Hole Insert, 22MM, Black, Tigerlink Hardware CPHP035	
1	OFA-LOGO	Offroad Animal Metal Logo	
1	FB-IMX-RJ-21-PR-ADRCP	ADR Compliance Plate MUX 21+	
2	TK-FB-IDM-RG-24	Tape Kit - D-MAX 24+, 3M5952, 2x 30x6mm, 2x 50x6mm, 2x 75x15mm	N/A
2	PWS-SIDE-300	Pinch Weld PWS53S - Side Bulb Seal 300mm	N/A
2	PWS-TOP-380	Pinch Weld PWS51T - Top Bulb Seal 380mm	N/A
<b>PREDATOR ONLY</b>			
1	M-0064R	MU-X MY25 Facelift Predator Wing Light Mesh RH	
1	M-0064L	MU-X MY25 Facelift Predator Wing Light Mesh LH	
<b>TORO ONLY</b>			
2	B-0649	Toro Antenna Bracket - 90 Degree Tall	
1	M-0065R	MU-X MY25 Facelift Toro Wing Light Mesh RH	

<p><b>1</b></p>	<p>M-0065L</p>	<p>MU-X MY25 Facelift Toro Wing Light Mesh LH</p>	
<p><b>2</b></p>	<p>LED Autolamps 80AW</p>	<p>LED AUTOLAMPS 80AW LED INDICATOR PARKER COMBO LIGHT, SINGLE BLISTER PACK</p>	

**PREDATOR Fasteners – Contained in Small Parts Kit Bag**

Qty	Part Number	Description
3	M6x12 BHCS BLACK ZINC	SCREW, BUTTON HEAD CAP, M6X12X1 GR12.9, ISO4042 ZnNi BLACK PASSIVATED FINISH
7	M6 X 12 CSK BZP	SCREW, COUNTERSUNK CAP, M6X12X1 Black ZP
36	M6x16 BHCS BLACK ZINC	SCREW, BUTTON HEAD CAP, M6X16X1 GR12.9, ISO4042 ZnNi BLACK PASSIVATED FINISH
39	M6 FLAT WASHER BLACK ZINC	M6 Flat Washer, 12x6.1x1, ISO4042 ZnNi BLACK PASSIVATED FINISH
23	M6 FLANGE NUT	Flange Nut, M6x1 G8.8 ZP
10	M6CN3MM	CAGE NUT M6x2.6-3.5
6	M8 X 20 HEX	Bolt Hex, M8X20x1.25, GR8.8 ZP
2	M8 X 16 BHCS BZP	SCREW, BUTTON HEAD CAP, M8X16X1.25 GR12.9, ISO4042 ZnNi BLACK PASSIVATED FINISH
4	M8 X 20 BHCS BLACK ZINC	SCREW, BUTTON HEAD CAP, M8X20X1.25, ISO4042 ZnNi BLACK PASSIVATED FINISH
4	M8 X 30 BHCS BLACK ZINC	SCREW, BUTTON HEAD CAP, M8X30X1.25, ISO4042 ZnNi BLACK PASSIVATED FINISH
8	M8 HD FLAT WASHER	M8 FLAT WASHER - High Tensile 19x8x1.9mm
10	M8 HD FLAT WASHER - BZP	M8 FLAT WASHER - High Tensile 19x8x2mm, ISO4042 ZnNi BLACK PASSIVATED FINISH
2	M8 NYW	Washer, M8, Nylon
6	M8 FLANGE NUT	Flange Nut, M8x1.25 G8.8 ZP
2	M8 NYLOC	NYLOC SELF LOCKING NUT, ST STL A2 ISO
13	M10 x 30	Bolt Hex, M10X30x[1.5], GR8.8 ZP
13	M10 FW LHD	WASHER, FLAT M10X28.5X2.5
9	M10 FLANGE NUT	Flange Nut, M10x1.5 G8.8 ZP
12	M12X30	Bolt Hex, M12X30x1.75, GR8.8 ZP
14	M12 FW LHD	M12 FW Large Heavy Duty
8	M12 FLANGE NUT	Flange Nut, M12x1.75 G8.8 ZP
2	M12 Nyloc nut	M12 NYLOC NUT
2	FB-IDM-RG-21-PR-ASM4	DMAX 21+ Tow Point Nut Plate
2	NP-COM-M10-190-ASM0	M10 LOLLYPOP NUT PLATE 190MM LONG

**TORO Fasteners – Contained in Small Parts Kit Bag**

Qty	Part Number	Description
3	M6x12 BHCS BLACK ZINC	SCREW, BUTTON HEAD CAP, M6X12X1 GR12.9, ISO4042 ZnNi BLACK PASSIVATED FINISH
7	M6 X 12 CSK BZP	SCREW, COUNTERSUNK CAP, M6X12X1 Black ZP
34	M6x16 BHCS BLACK ZINC	SCREW, BUTTON HEAD CAP, M6X16X1 GR12.9, ISO4042 ZnNi BLACK PASSIVATED FINISH
37	M6 FLAT WASHER BLACK ZINC	M6 Flat Washer, 12x6.1x1, ISO4042 ZnNi BLACK PASSIVATED FINISH
23	M6 FLANGE NUT	Flange Nut, M6x1 G8.8 ZP
10	M6CN3MM	CAGE NUT M6x2.6-3.5
6	M8 X 20 HEX	Bolt Hex, M8X20x1.25, GR8.8 ZP
2	M8 X 16 BHCS BZP	SCREW, BUTTON HEAD CAP, M8X16X1.25 GR12.9, ISO4042 ZnNi BLACK PASSIVATED FINISH
8	M8 X 20 BHCS BLACK ZINC	SCREW, BUTTON HEAD CAP, M8X20X1.25, ISO4042 ZnNi BLACK PASSIVATED FINISH
4	M8 X 30 BHCS BLACK ZINC	SCREW, BUTTON HEAD CAP, M8X30X1.25, ISO4042 ZnNi BLACK PASSIVATED FINISH
8	M8 HD FLAT WASHER	M8 FLAT WASHER - High Tensile 19x8x1.9mm
14	M8 HD FLAT WASHER - BZP	M8 FLAT WASHER - High Tensile 19x8x2mm, ISO4042 ZnNi BLACK PASSIVATED FINISH
2	M8 NYW	Washer, M8, Nylon
6	M8 FLANGE NUT	Flange Nut, M8x1.25 G8.8 ZP
2	M8 NYLOC	NYLOC SELF LOCKING NUT, ST STL A2 ISO
13	M10 x 30	Bolt Hex, M10X30x[1.5], GR8.8 ZP
13	M10 FW LHD	WASHER, FLAT M10X28.5X2.5
9	M10 FLANGE NUT	Flange Nut, M10x1.5 G8.8 ZP
12	M12X30	Bolt Hex, M12X30x1.75, GR8.8 ZP
14	M12 FW LHD	M12 FW Large Heavy Duty
8	M12 FLANGE NUT	Flange Nut, M12x1.75 G8.8 ZP
2	M12 Nyloc nut	M12 NYLOC NUT
2	FB-IDM-RG-21-PR-ASM4	DMAX 21+ Tow Point Nut Plate
2	NP-COM-M10-190-ASM0	M10 LOLLYPOP NUT PLATE 190MM LONG

## TOOLS REQUIRED

The following tools will be required to install the product.

<b>Hand Tools</b>	<b>Power Tools</b>	<b>Workshop Equipment</b>
Metric Socket Set 8-19mm	Electric/Air Impact Driver (Optional)	Panel Stand or Soft Blanket
Socket Extension Bar	Air hacksaw or Jigsaw	Lifting Trolley
Metric Spanner Set 8-19mm	Multi-tool or Angle grinder	Isopropyl Alcohol
Hex (Allen) Key Set 4-6mm	Soldering Iron (Toro Only)	Clean Workshop Rag
Trim Removal Tool		Marker Pen
Flat Blade Screwdriver Set		Measuring Tape
Phillips Head Screwdriver Set		Masking Tape
Utility Knife		Cable Ties
Side Cutters		Black spray paint
Pliers		Heat shrink (Toro Only)
Deburring Tool		Electrical tape (Toro Only)
Wire Strippers (Toro Only)		Sikaflex adhesive
T25 Torx Bit (Camera Relocation Only)		

# WORKSHOP SAFETY

It is the responsibility of the installer to always complete works in a safe manner. Make sure the following safety equipment is available and precautions are observed whilst fitting this product.

<p>Hearing Protection</p> 	<p>Always wear ear protection when using power tools.</p>
<p>Eye Protection</p> 	<p>Ensure eye protection is always worn when cutting or drilling.</p>
<p>Manual Handling</p> 	<p>Do not attempt to lift bar assemblies or rock sliders on your own.</p> <p>Always use two people to lift or use mechanical lifting aid such as hydraulic lifting trolley.</p>
<p>Vehicle Support</p> 	<p>Always ensure vehicle is properly supported when working on it. Do not attempt to fit products whilst suspension work is being carried out. Do not work under a vehicle supported only by a jack.</p>



1. Remove number plate from bumper and set aside.
2. Open the bonnet.
3. Remove 2x plastic push clips holding the factory air intake scoop. To remove each push clip, lever the centre section upwards using a flat blade screwdriver or trim tool, as shown. Retain these clips.
4. Remove the factory air intake scoop and set aside. Take care not to drop anything into the intake.

**TOOLS REQUIRED**

Phillips head screwdriver  
  
Flat blade screwdriver  
or  
Trim tool

**FASTENERS**

2x plastic push clips  
  
Retain

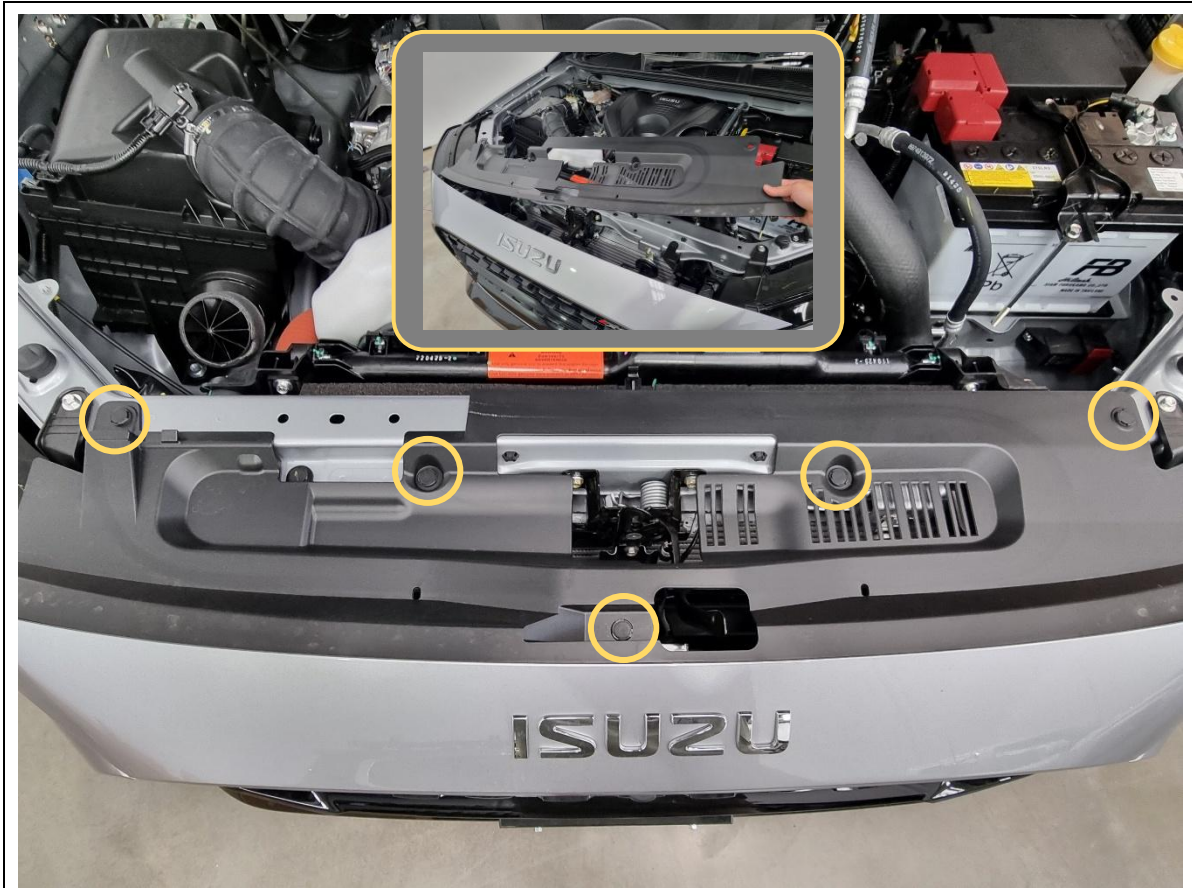

5. Remove 5x plastic push clips holding the radiator top cover. Retain these clips.
6. Pull upwards and release the 8x tabs/clips holding the front edge of the radiator top cover to the bumper/grille assembly. Set aside.

**TOOLS REQUIRED**

Flat blade screwdriver  
or  
Trim tool

**FASTENERS**

5x plastic push clips  
  
Retain

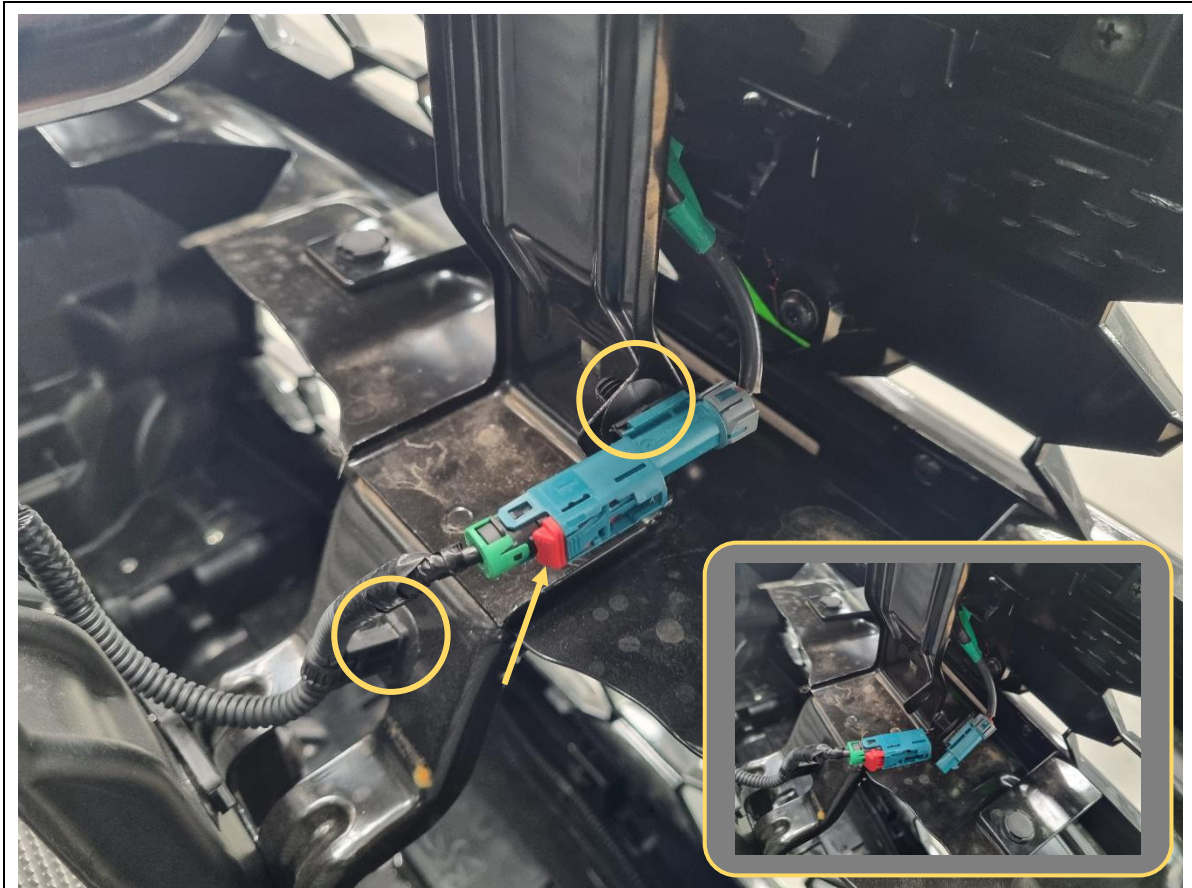

7. Some models come with a front 360 degree camera.

Locate the plug behind the grille. Pull out the red tab (see arrow above), then unplug the camera harness.

8. Also use a flat blade screwdriver or trim tool and unclip the 2x plastic clips (circled above) holding the harness to the body.

**TOOLS REQUIRED**

Flat blade screwdriver  
or  
Trim tool

**FASTENERS**

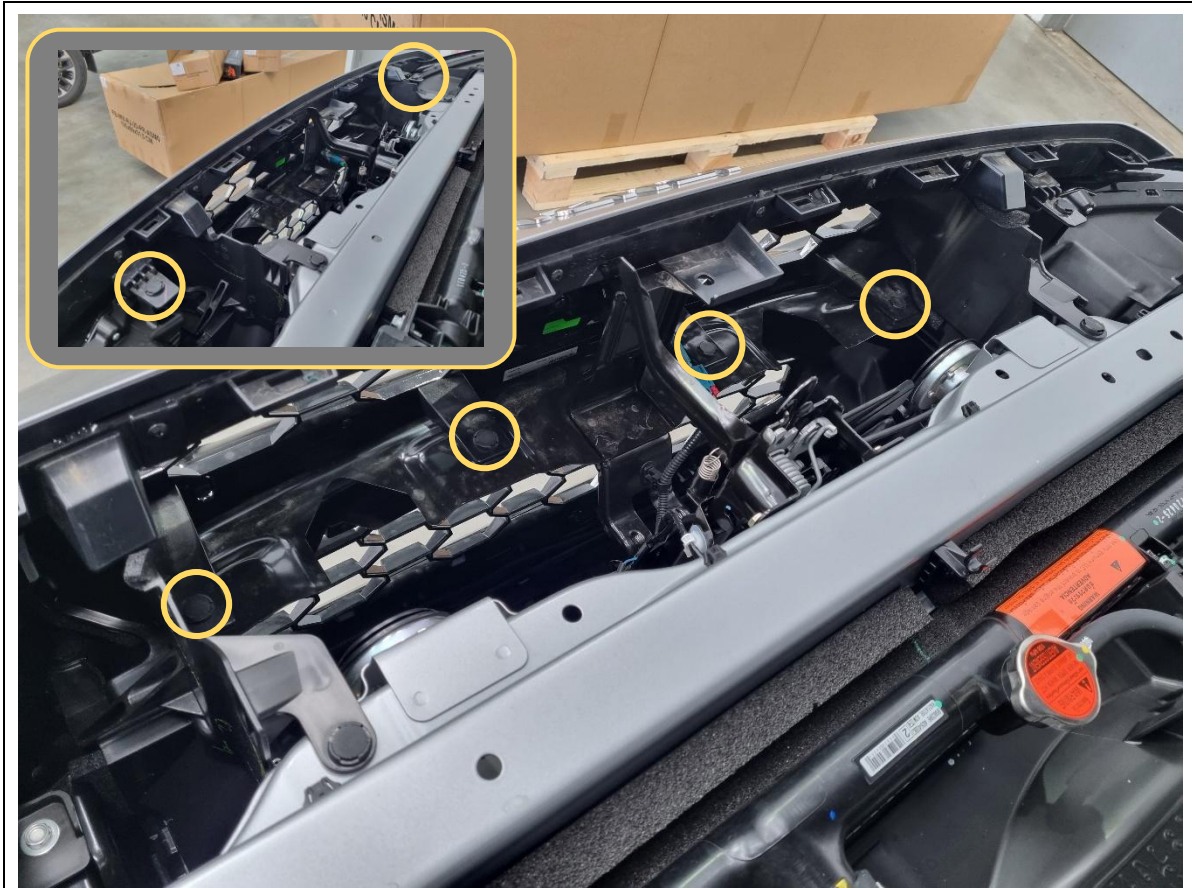

9. Remove 6x plastic push clips holding the grille. There are 2x clips on the top edge, and 4x clips on the cross member on the inside of the grille.

Retain these clips.

**TOOLS REQUIRED**

Flat blade screwdriver  
or  
Trim tool

**FASTENERS**

6x plastic push clips

Retain



10. In the front wheel well area, remove 1x plastic push clip holding the bumper to the quarter panel. Do this on both sides and retain the clips.

**TOOLS REQUIRED**

Flat blade screwdriver  
or  
Trim tool

**FASTENERS**

2x plastic push clip  
  
Retain

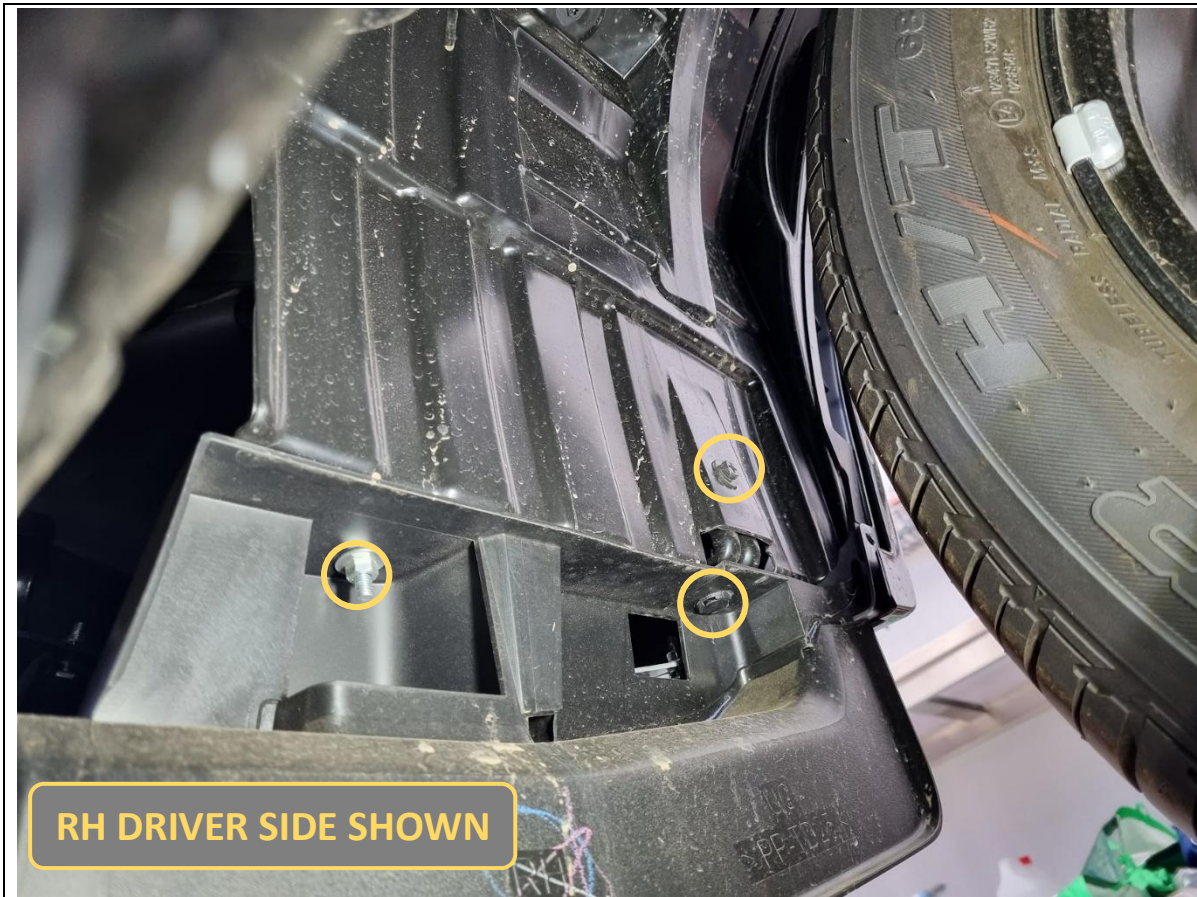

<p>11. Looking from within the front wheel well towards the back the bumper, remove the following:</p> <ul style="list-style-type: none"> <li>a. 1x 10mm hex screw holding wheel arch liner to outer bumper bracket (top right circle)</li> <li>b. 1x 10mm hex nut holding bottom of bumper to wheel arch liner (bottom left circle)</li> <li>c. 1x plastic push clip holding bottom of bumper to outer bumper bracket (bottom right circle)</li> </ul>	<p><b>TOOLS REQUIRED</b></p> <p>10mm socket/spanner</p> <p>Flat blade screwdriver or Trim tool</p>
	<p><b>FASTENERS</b></p> <p>2x 10mm hex screw 2x 10mm hex nut 2x plastic push clip</p> <p>Discard</p>



12. On the underside of the bumper at the front, remove 2x plastic push clips (1x per side) holding the bumper to the inner bumper bracket. Clips are located near the front tie down hooks on each side.

**TOOLS REQUIRED**

Flat blade screwdriver  
or  
Trim tool

**FASTENERS**



13. Unclip the LH corner of the bumper by pulling away and outwards from the outer corner, starting from the outside and working in.

**TOOLS REQUIRED**

**FASTENERS**

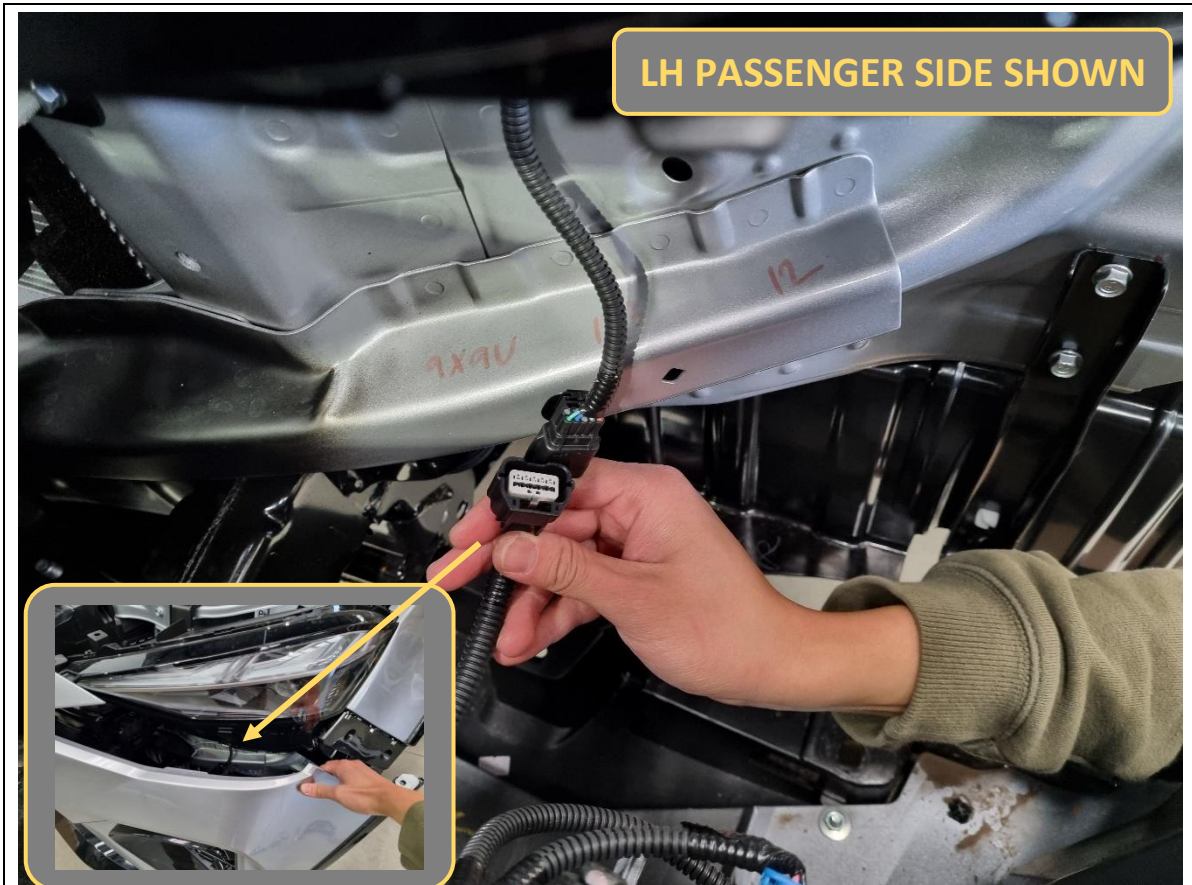

14. When bumper is loose, reach in and disconnect the 1x bumper harness connector located under the left-hand headlight.

**TOOLS REQUIRED**

**FASTENERS**



15. Unclip the RH corner, then fully remove the bumper from car and set aside.

**TOOLS REQUIRED**

**FASTENERS**



16. Remove the 1x 10mm hex bolt and 1x Phillips head screw securing the outer plastic bumper clip. Retain the hex bolt.
17. Remove the outer plastic bumper clip. A firm tug will be required to release the clips. Discard afterwards.
18. Do this for both sides.

**TOOLS REQUIRED**

Phillips head screwdriver  
10mm socket

**FASTENERS**

2x Phillips head screw (discard)  
2x factory 10mm hex bolt (retain)

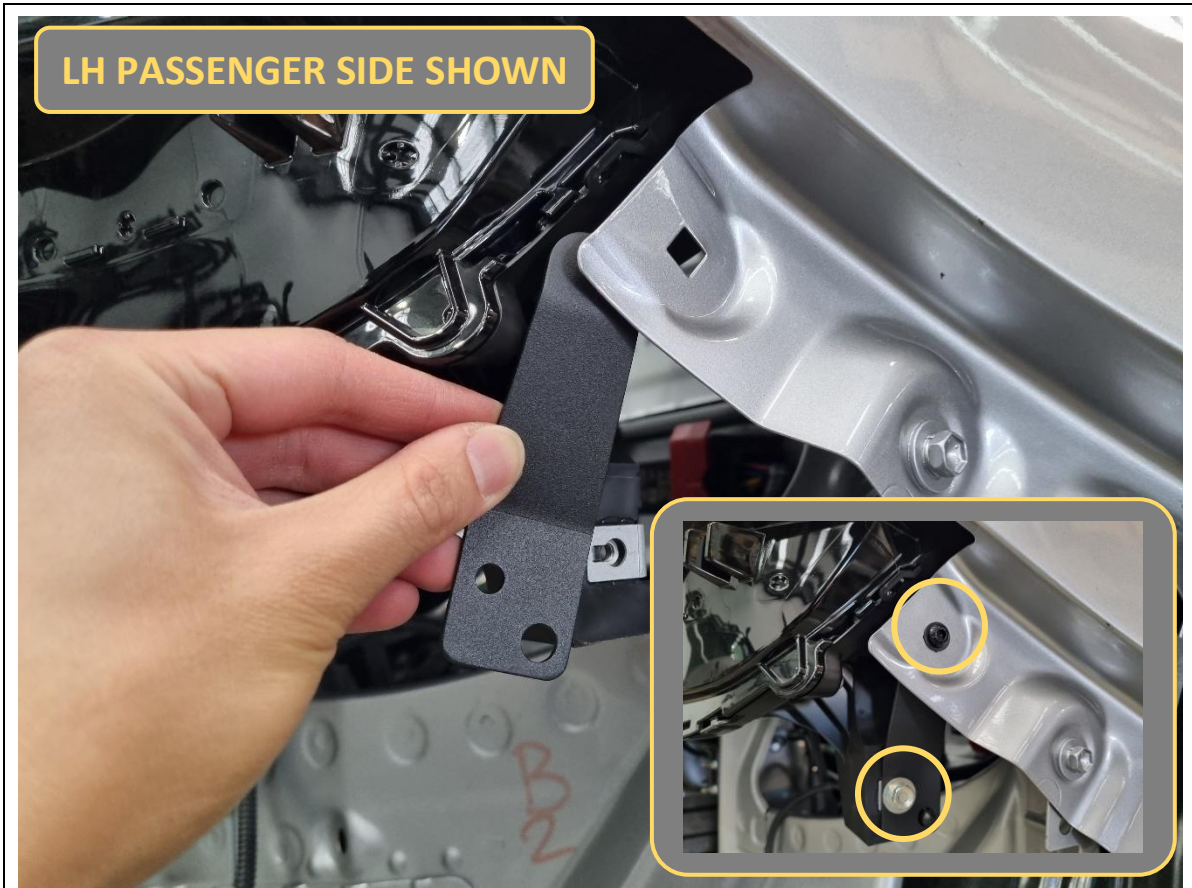

19. Fit the B-1585 headlight brackets in between the headlight and quarter panel.

The lower most hole in the bracket sits on the round keying stud on the leadlight.

The top of the bracket sits behind the quarter panel.

20. Secure the quarter panel to the embedded nut in the top of each bracket with 1x M6x16 black button head bolt and black washer.

21. Secure the bottom of each bracket to the headlight using the 10mm hex bolts retained from Step 16.

**TOOLS REQUIRED**

4mm hex/Allen key  
10mm socket/spanner

**FASTENERS**

2x M6x16 black button head bolt  
2x M6 black flat washer  
  
2x factory 10mm hex bolts  
(retained from Step 16)



**LH PASSENGER SIDE SHOWN**

- 22. For light coloured vehicles, it is recommended to paint the exposed bottom section of the fender guard black.
- 23. Wipe clean and mask off the area with masking tape, then paint black.
- 24. Remove masking tape and allow paint to dry while mounts are being fitted.

**TOOLS REQUIRED**

Masking tape  
Black spray paint

**FASTENERS**

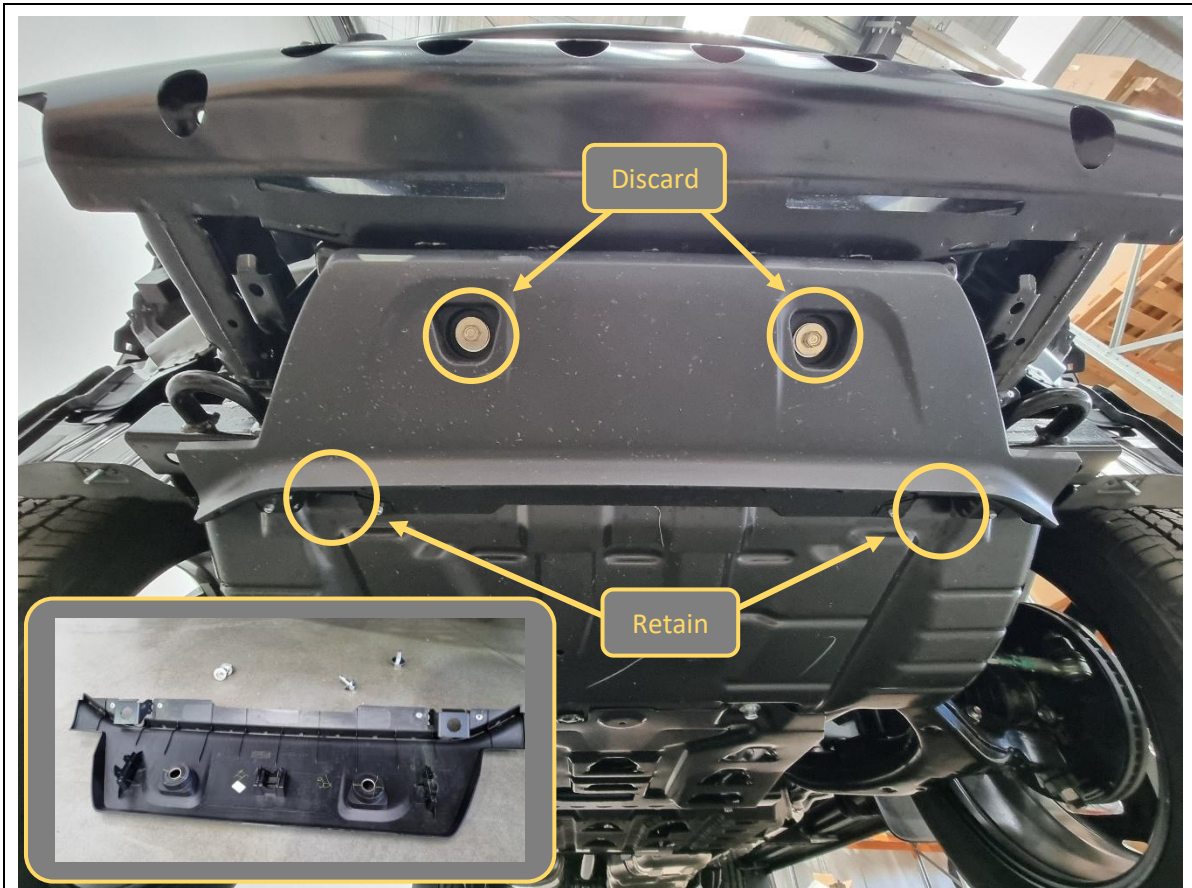

25. Underneath the vehicle, remove 2x 12mm hex bolts (front) and 2x 14mm hex bolts (rear) holding the plastic splash shield.

Retain the 14mm hex bolts at the rear.

26. Pull downwards to release the tabs in middle and remove the splash shield.

**TOOLS REQUIRED**

12mm socket  
14mm socket

**FASTENERS**

2x 12mm hex bolt (discard)  
2x 14mm hex bolt (retain)



- 27. Remove the 4x 14mm hex bolts securing the impact beam to the chassis.
- 28. Remove and discard the impact beam. Retain bolts for fitting of mounts.

**TOOLS REQUIRED**

14mm socket

**FASTENERS**

4x factory 14mm hex bolts

Retain

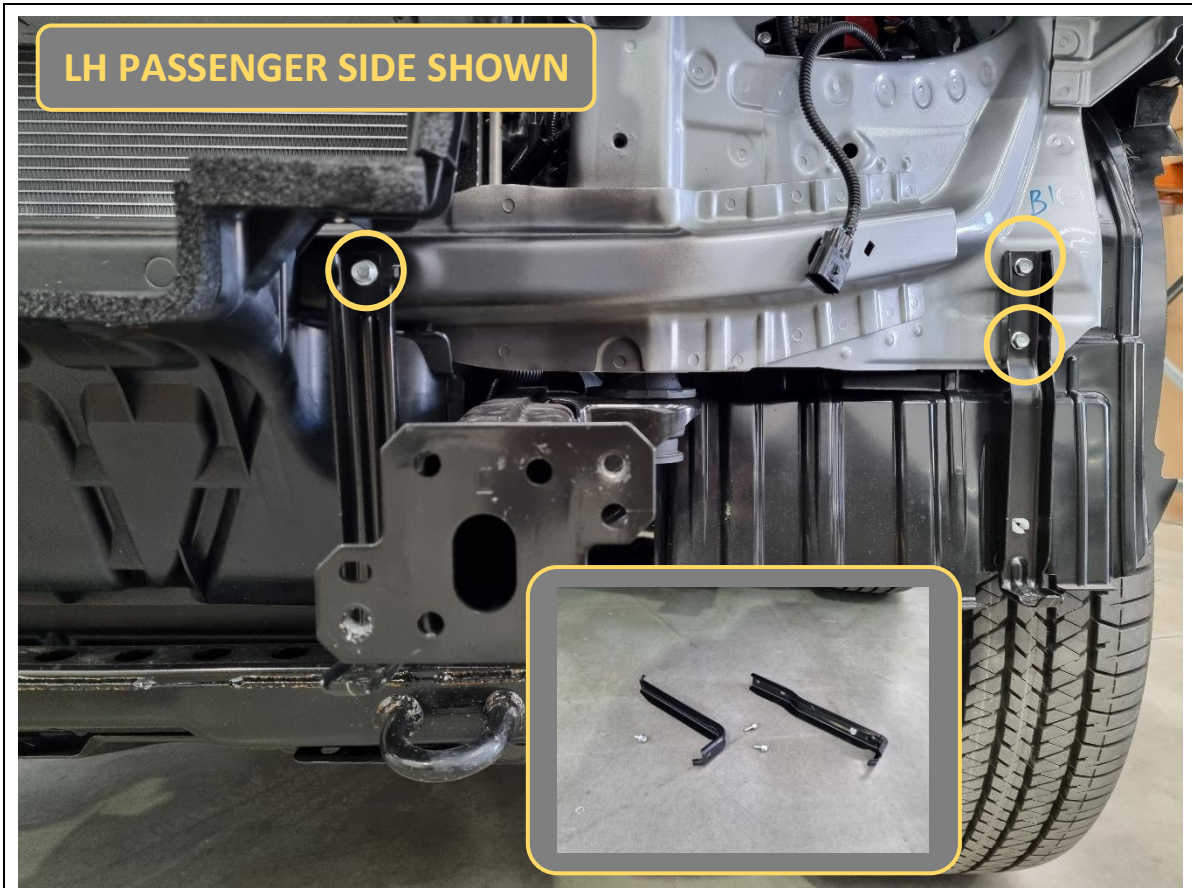

- 29. Remove the 2x 10mm hex bolts securing each outer bumper support bracket.
- 30. Remove the 1x 10mm hex bolt securing each inner bumper support bracket.
- 31. Remove and discard the bumper supports.

**TOOLS REQUIRED**

10mm socket/spanner

**FASTENERS**

6x 10mm factory hex bolts

Discard

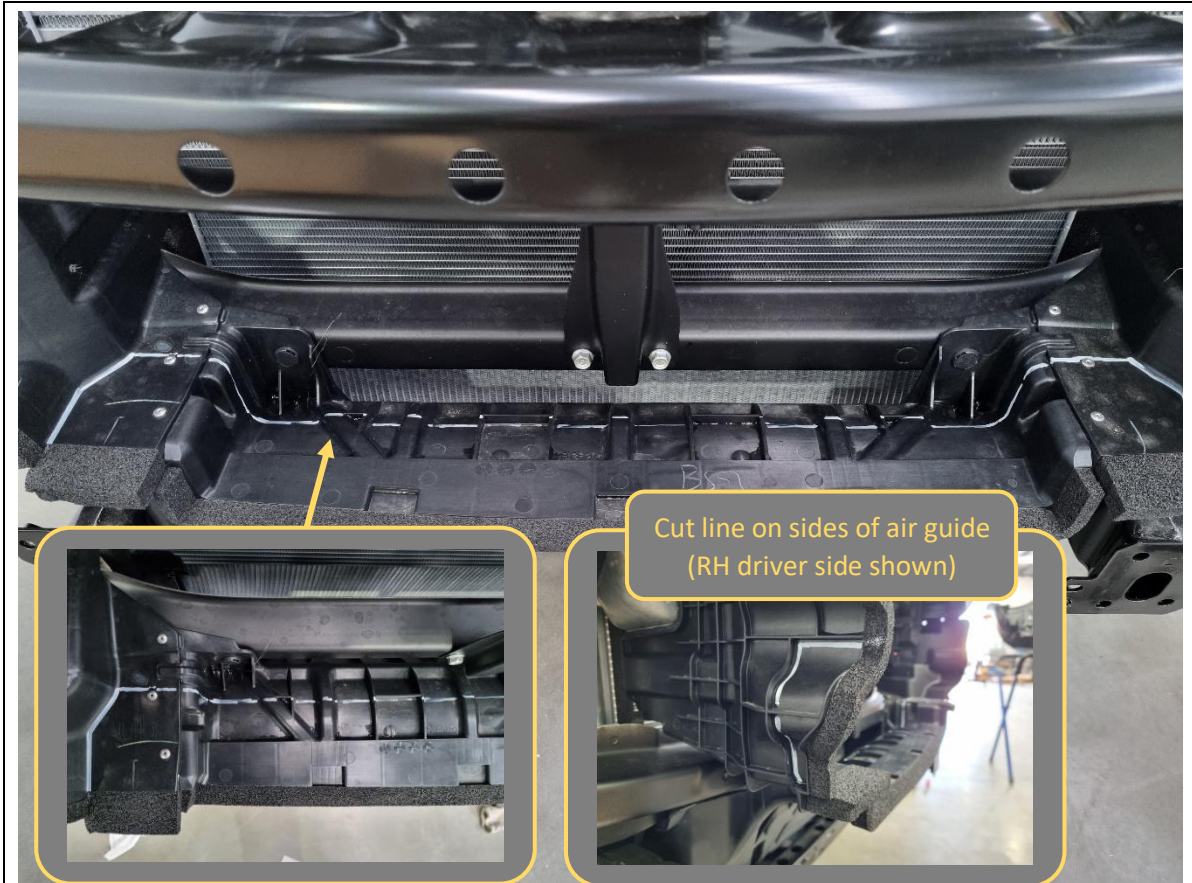

32. The plastic lower air guide needs to be trimmed. Use a marker pen and mark a cut line, as shown.

**TOOLS REQUIRED**

Marker pen

**FASTENERS**

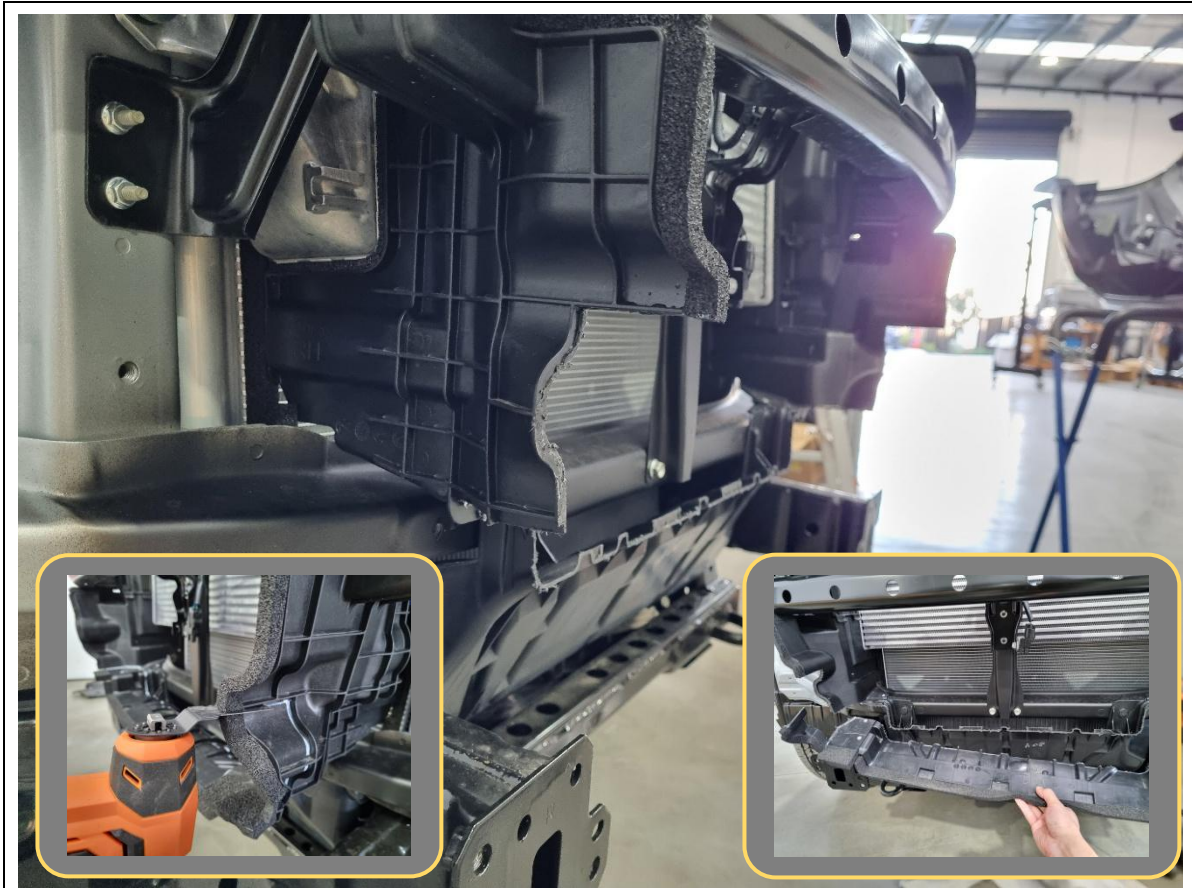

33. Trim the air guide along the marking with an oscillating multi-tool or similar.

The air guide can be removed and trimmed whilst off the car if required. It is held on with 4x plastic push clips.

34. Deburr sharp edges after trimming with a deburring tool or utility knife.

**TOOLS REQUIRED**

Oscillating multi-tool  
or similar

Utility knife  
or  
Deburring tool

**FASTENERS**



<p>35. Time to strip the bumper.</p> <p>For Predator bars, there is the option to relocate the front 360 degree camera if fitting with a Stealth Hoop or Rally Hoop bolt-on top tube.</p> <p>If choosing to relocate, remove the camera assembly from the back of the grille by removing 2x T25 Torx screws.</p> <p>Otherwise skip this step.</p>	<p><b>TOOLS REQUIRED</b></p> <p>T25 Torx bit</p>
	<p><b>FASTENERS</b></p> <p>2x T25 Torx screws</p>

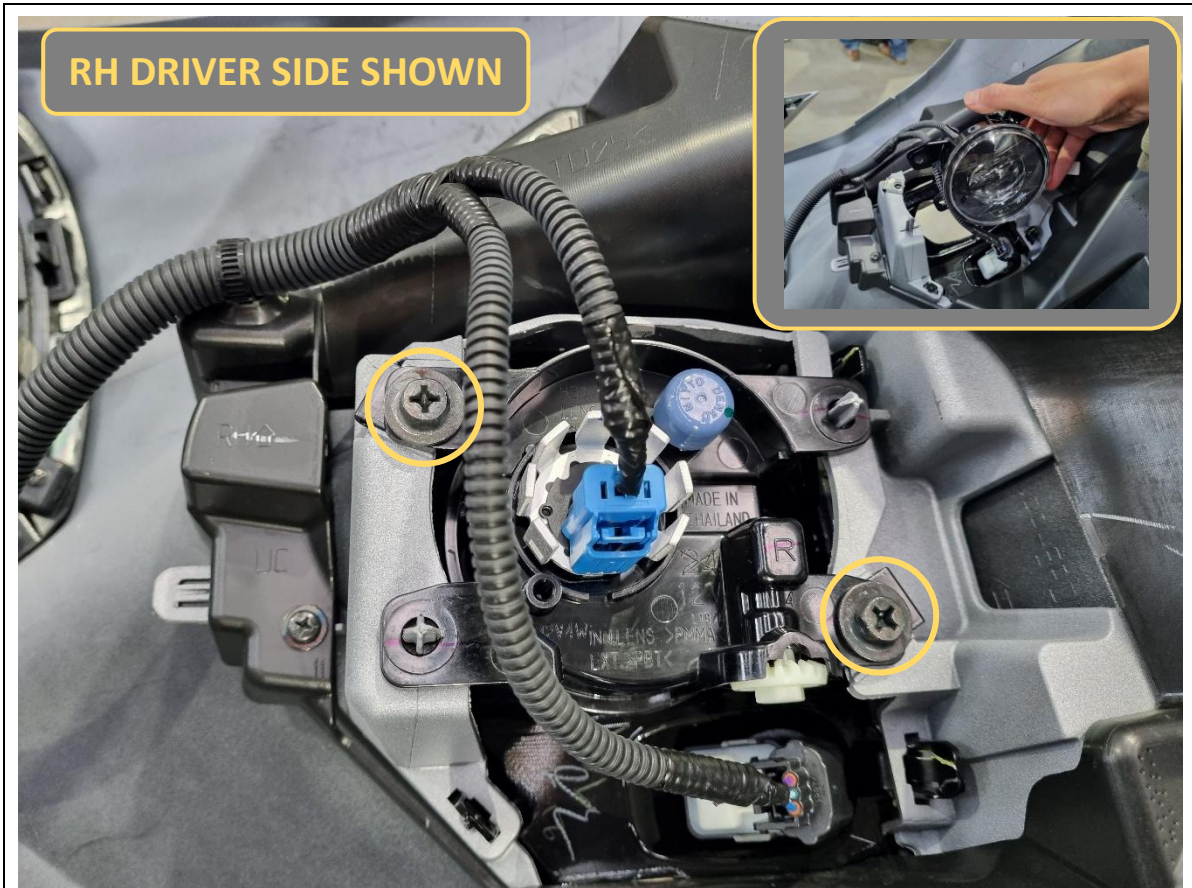

36. If equipped, remove 2x 10mm hex bolts securing each fog light on the back of the bumper.

**TOOLS REQUIRED**

10mm socket/spanner

**FASTENERS**

4x 10mm hex bolt

Discard

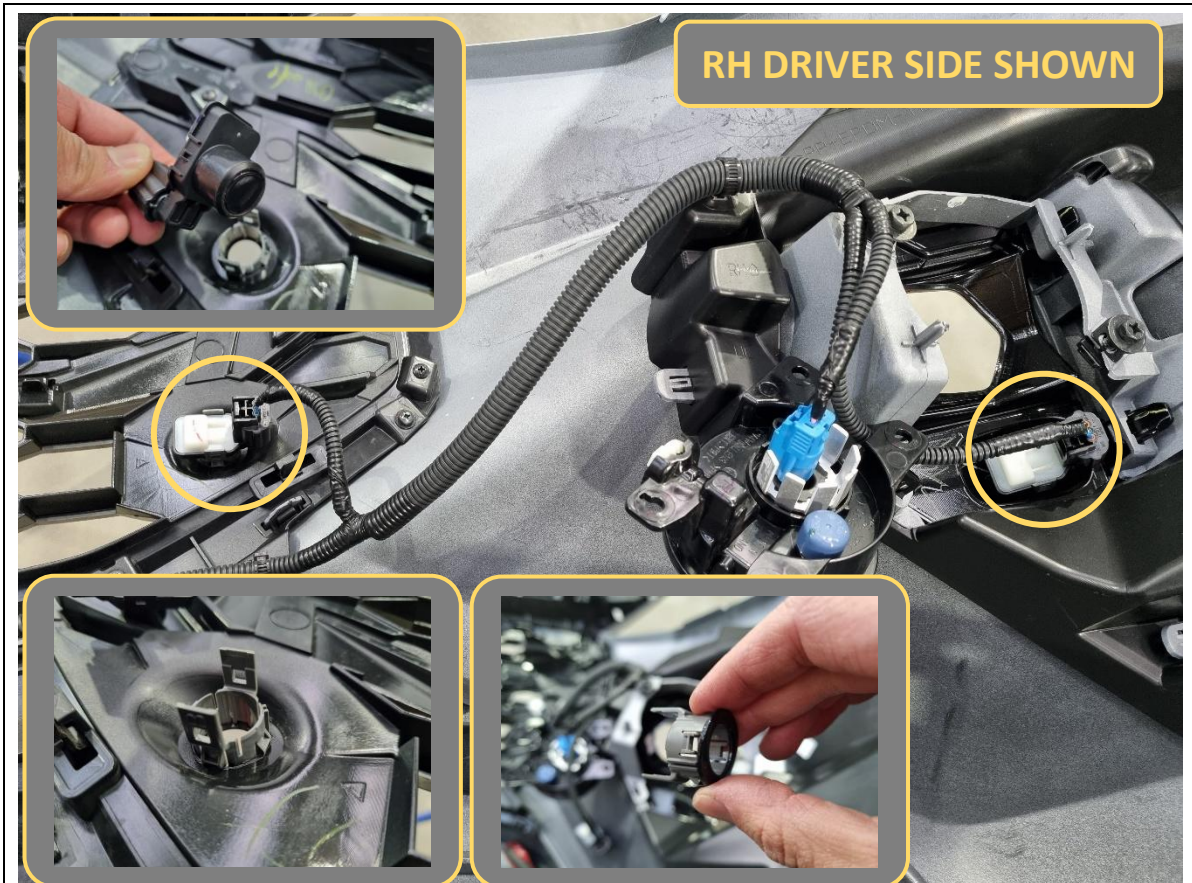

<p>37. If equipped, take note of the orientation of all 4x parking sensors. The plugs should all be pointing outwards to the side of the vehicle.</p> <p>38. Spread open the tabs on the plastic sensor holder and unclip each parking sensor.</p>	<p><b>TOOLS REQUIRED</b></p>
<p>39. Press down on the tabs on the sensor holders and remove them from the bumper. Keep track of the sensor holder orientation.</p> <p>40. Re-fit the sensor holders back onto the parking sensors in the same original orientation.</p>	<p><b>FASTENERS</b></p>



41. Cut the cable tie clips securing the harness to the bumper and strip it off the vehicle. Set the harness aside.

**TOOLS REQUIRED**

Side cutters

**FASTENERS**

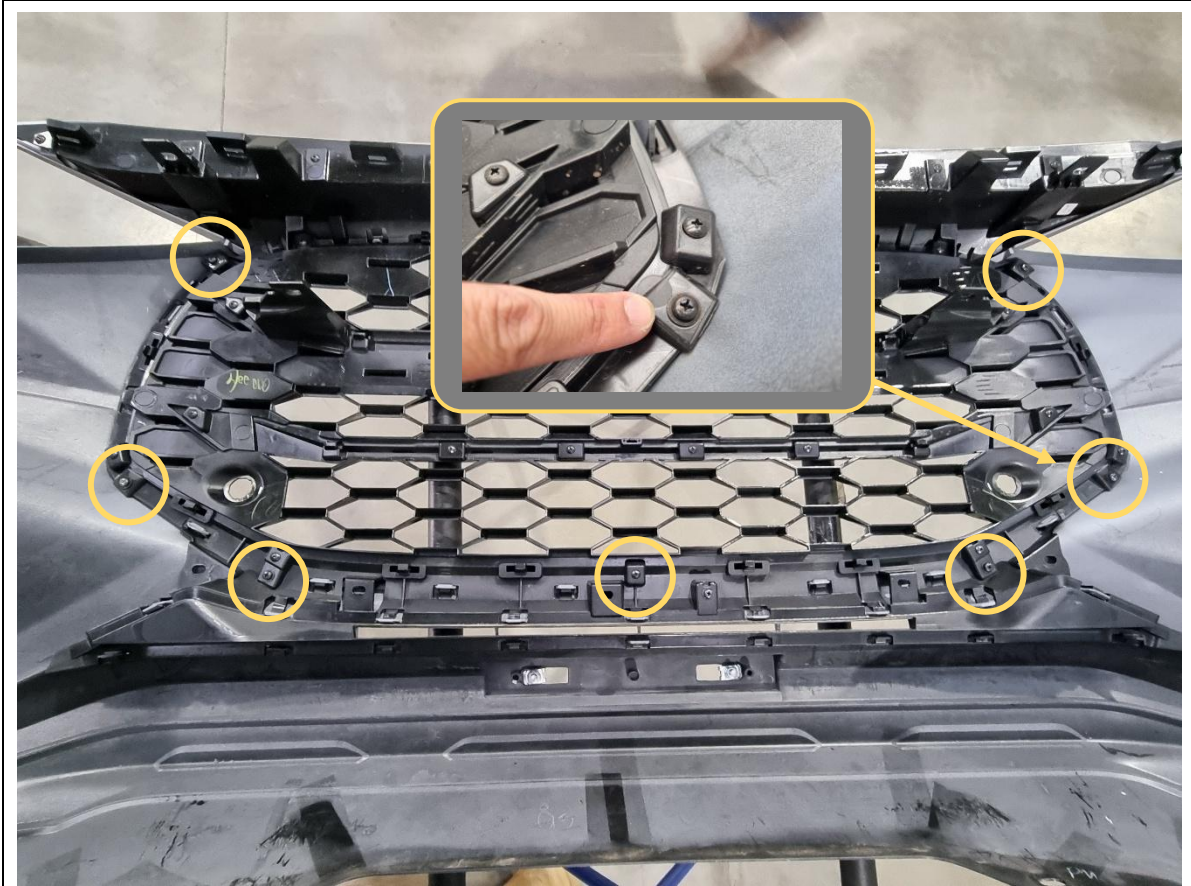

42. The grille needs to be separated from the bumper.

Remove 7x Phillips head screws as shown.

**TOOLS REQUIRED**

Phillips head screwdriver

**FASTENERS**

7x Phillips head screws

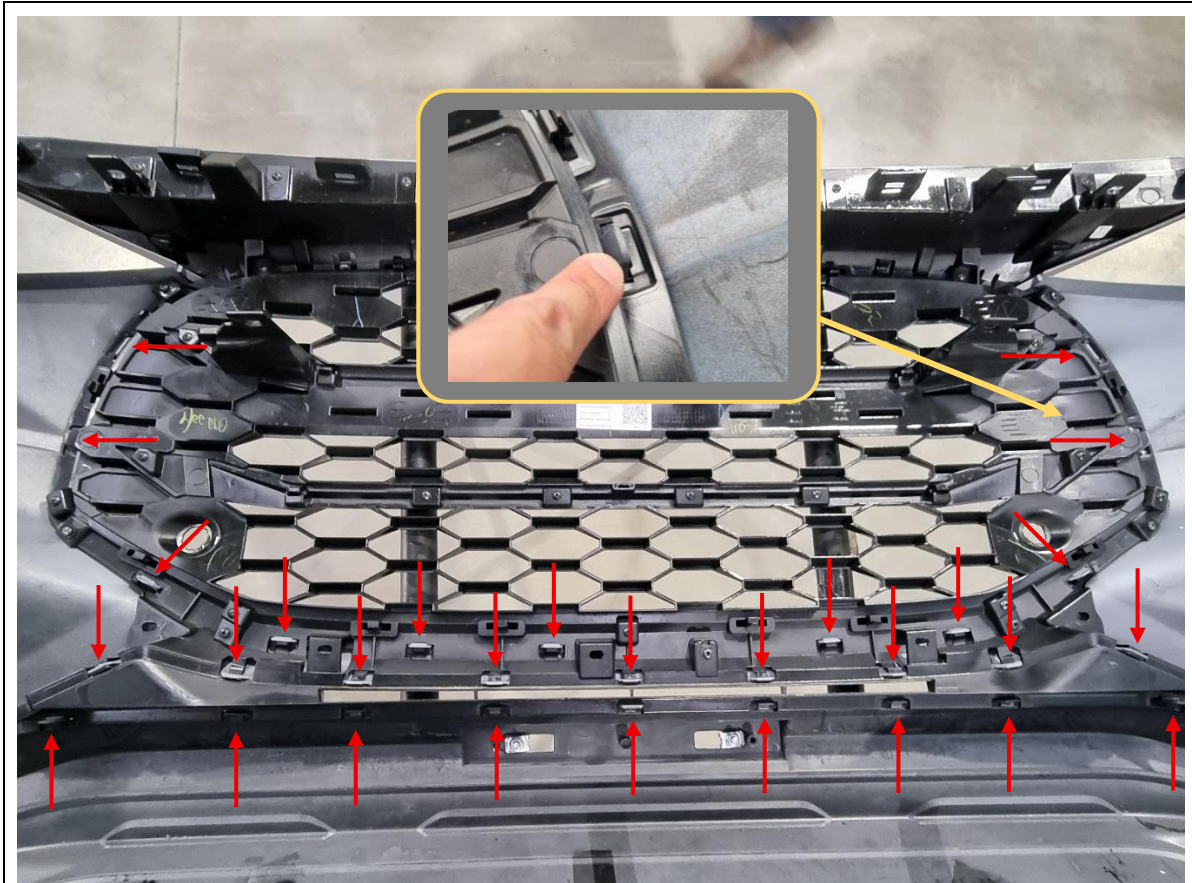

43. There are 29x tabs holding the grille to the bumper.

Use a flat blade screwdriver or trim tool to assist with releasing them.

44. Fully separate the grille from the bumper. The bumper can be discarded.

**TOOLS REQUIRED**

Flat blade screwdriver  
or  
Trim tool

**FASTENERS**

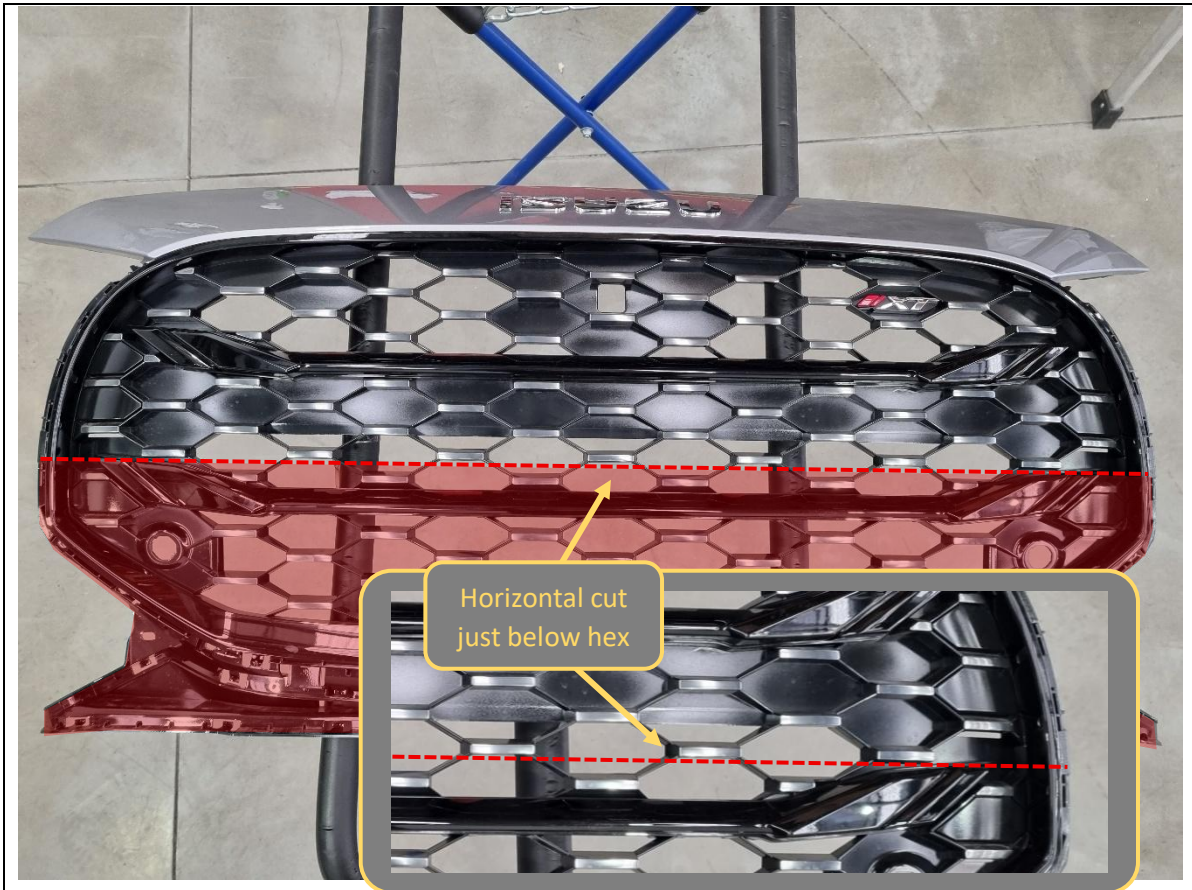

<p>45. The grille will need to be cut as shown.</p>	<p><b>TOOLS REQUIRED</b></p>
	<p><b>FASTENERS</b></p>

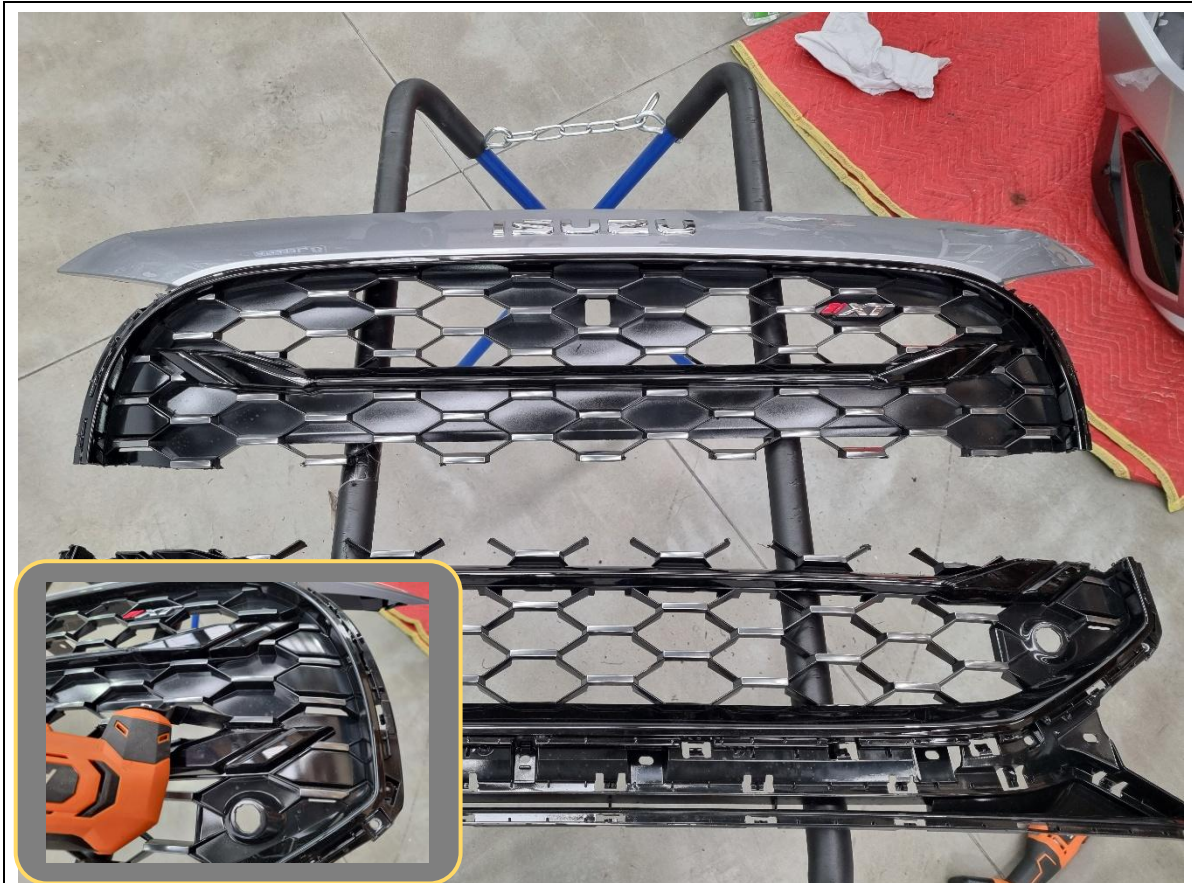

<p>46. Trim the grille as detailed on the previous page.</p> <p>47. Discard the lower section of the grille.</p> <p>48. Clean up the trimmed edges with a deburring tool or utility knife.</p>	<p><b>TOOLS REQUIRED</b></p> <p>Oscillating multi-tool or similar</p> <p>Deburring tool or Utility knife</p>
	<p><b>FASTENERS</b></p>

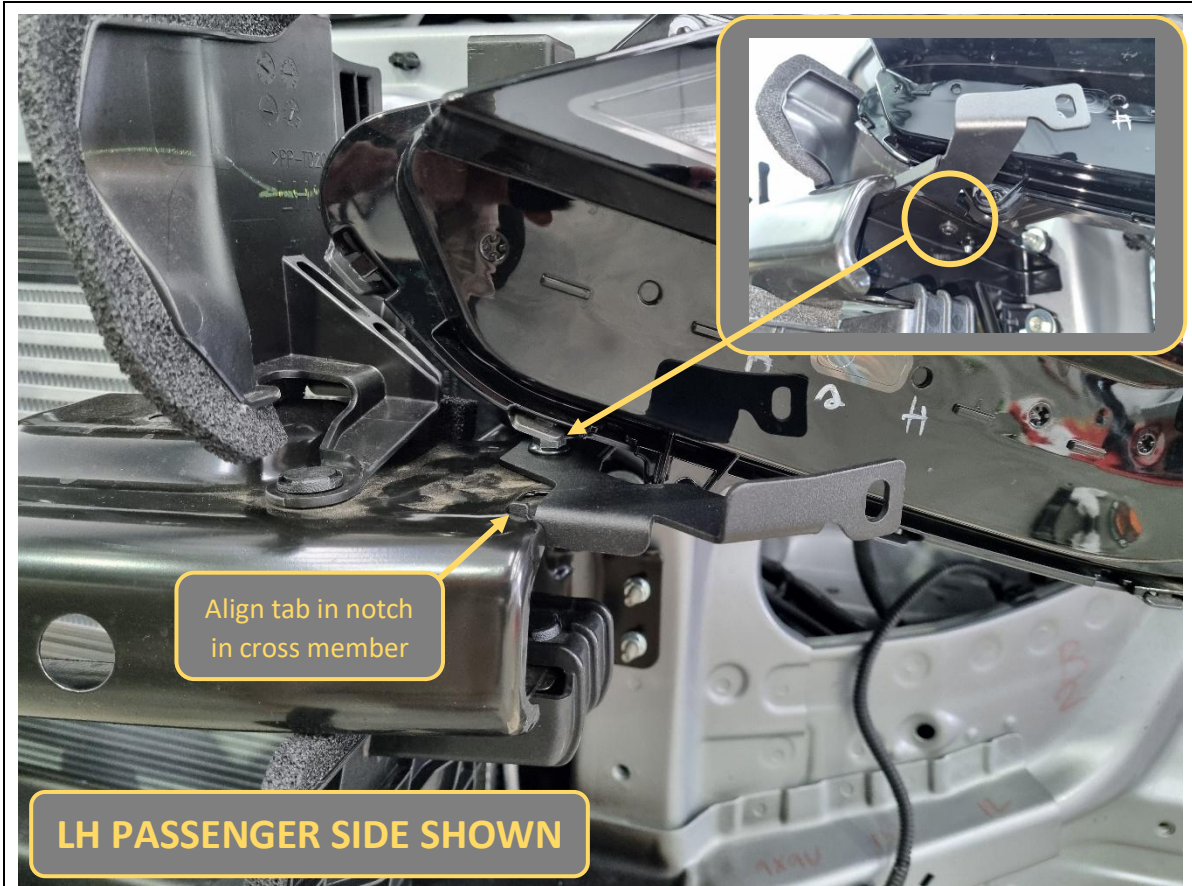

<p>49. Fit the B-1584 grille infill support brackets to the upper cross member, just inside of the headlights.</p> <p>Align the tab on the bracket into the small notch in the upper cross member.</p>	<p><b>TOOLS REQUIRED</b></p> <p>4mm hex/Allen key</p>
<p>50. Secure each bracket with 1x M6x16 black button head bolt, black washer and flange nut. Have the bolt head underneath and the nut on top.</p>	<p><b>FASTENERS</b></p> <p>2x M6x16 black button head 2x M6 black flat washer 2x M6 flange nut</p>



- 51. Re-fit the grille, radiator top cover and air intake scoop, using original plastic push clips.
- 52. If the camera is still in the grille, re-connect it now and clip the harness back in.

**TOOLS REQUIRED**

**FASTENERS**

13x plastic push clips

Retained from Step 3, 5 & 9



- 53. Clean the highlight surfaces underneath the headlight and on the outside of the grille with isopropyl alcohol and clean rag. Do this on both sides.
- 54. Also clean the supplied metal grille infill pieces (see top right inset photo), to ensure there are no contaminants or oil residues.

**TOOLS REQUIRED**

Isopropyl alcohol  
Clean workshop rag

**FASTENERS**

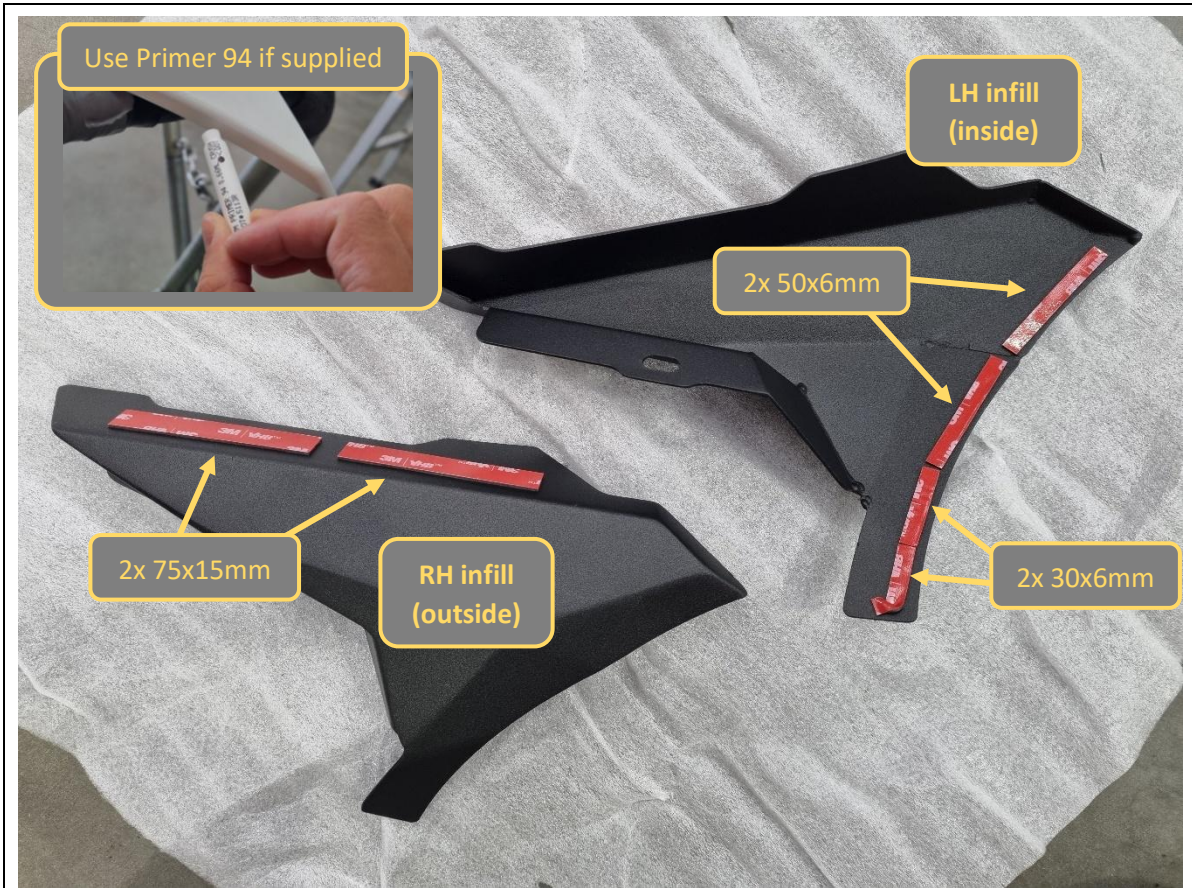

<p><b>Note:</b> If the tape kit comes supplied with a 3M Primer 94 ampoule, break the bulb on it activate primer dispensing. Apply primer to the cleaned surfaces.</p> <p><b>Allow at least 5 minutes for the primer to chemically bond to the surfaces before applying tape.</b></p>	<p><b>TOOLS REQUIRED</b></p> <p>Primer 94 (if supplied)</p>
<p>55. Apply supplied 3M VHB tape strips to the 2x grille infills as shown.</p> <p>Use 1x full tape kit per infill.</p> <p>Large strips are on the top flange outer surface of both infills. Refer to RH infill in image above.</p> <p>Small strips are on the inside edge of both infills. Refer to LH infill in image above.</p>	<p><b>FASTENERS</b></p>

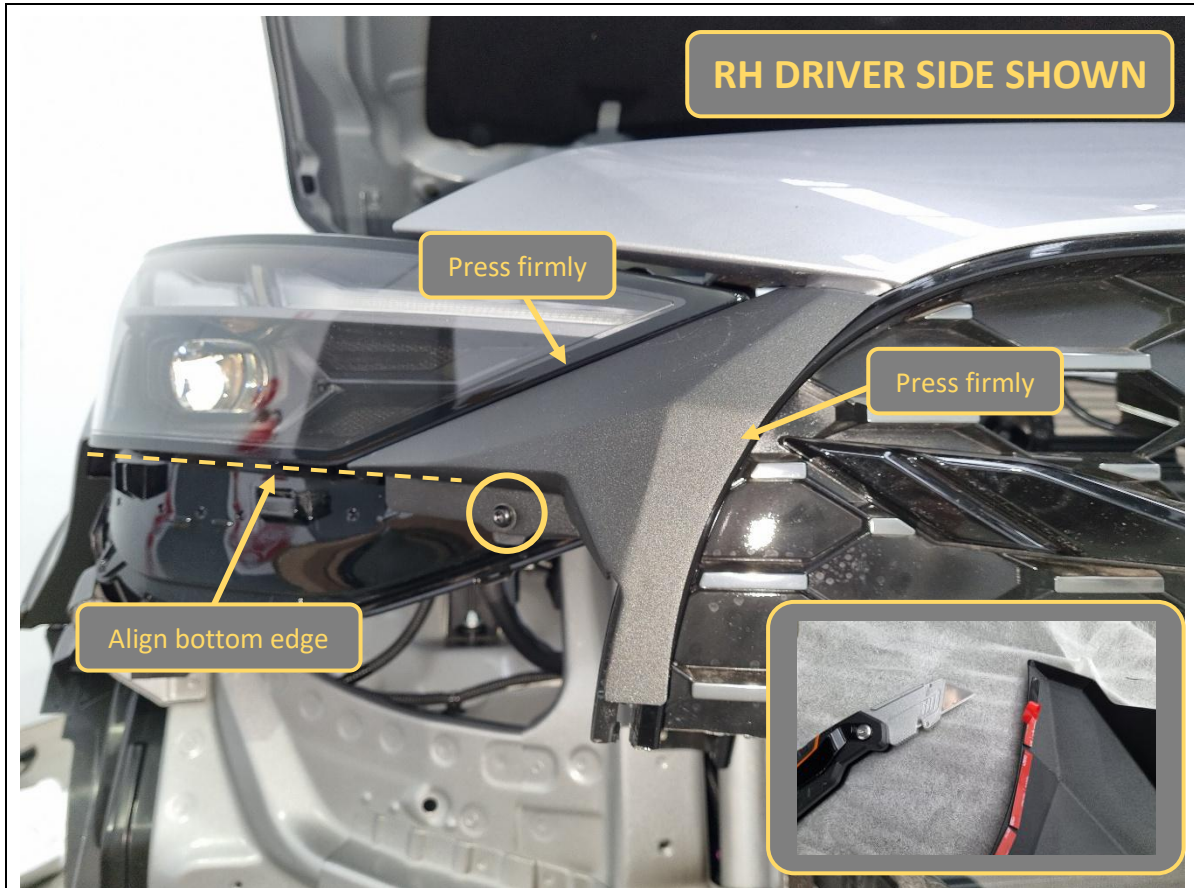

56. With a utility knife, peel off the red backing film for the tape strips, then adhere each grille infill to the underside of the headlight, and to the outer edge of the grille.

57. Hold the infills in place and press firmly up against the headlight and grille for at least 20 seconds for the tape to properly adhere.

58. Secure the bottom of each infill to the B-1584 grille infill support brackets using 1x M6x16 black button head bolt, black washer and flange nut.

**TOOLS REQUIRED**

Utility knife

4mm hex/Allen key

**FASTENERS**

2x M6x16 black button head bolt

2x M6 black flat washer

2x M6 flange nut

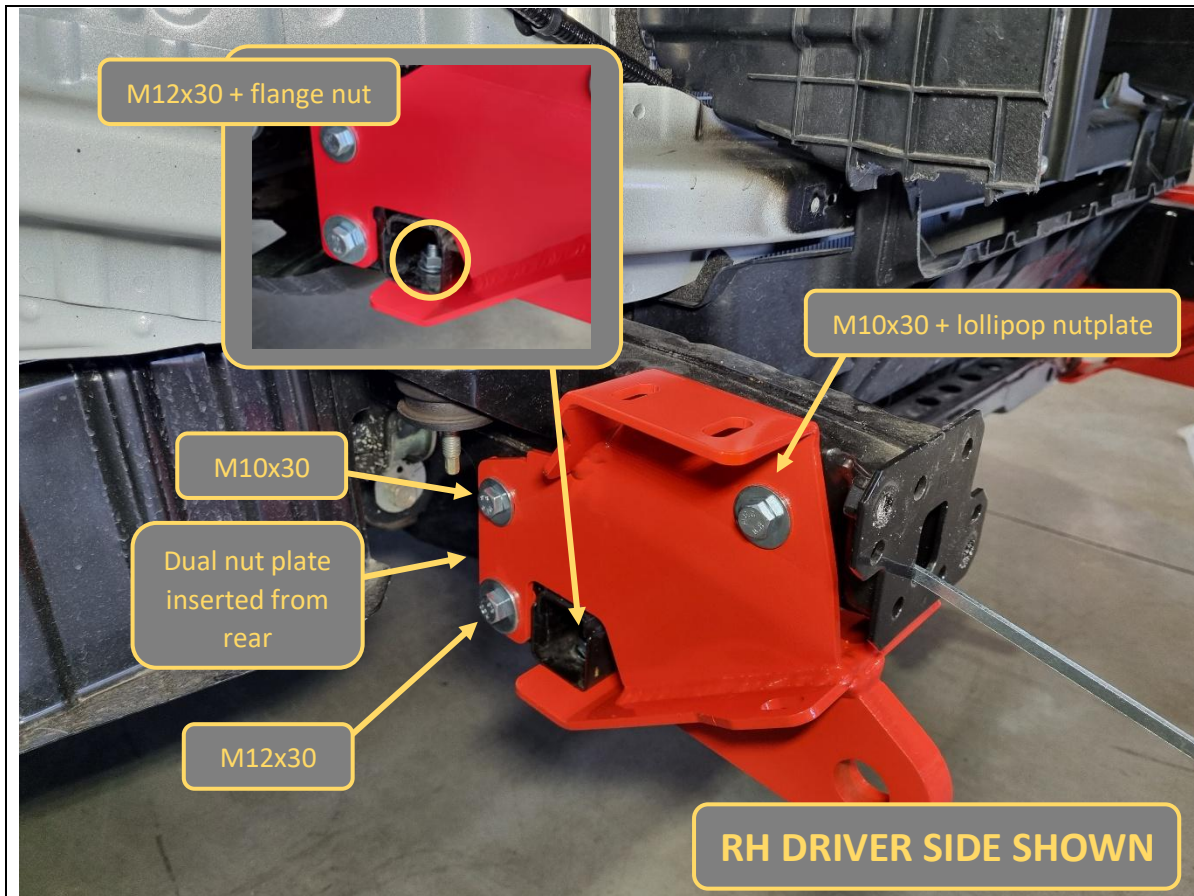

<p>59. Fit the tow point to the outside of the chassis rail.</p> <p>60. Loosely secure the bottom of the tow point to the horizontal chassis cross member with 1x M12x30 hex bolt, heavy-duty washer and flange nut.</p> <p>61. Insert 1x M10 lollipop nutplate through the front opening of the chassis rail, then loosely secure to the tow point with 1x M10x30 hex bolt and heavy-duty washer.</p> <p>62. Insert the dual nutplate through the back of the chassis drop member and loosely secure to the tow point with 1x M12x30 hex bolt, 1x M10x30 hex bolt and heavy-duty washers.</p> <p>63. Keep all bolts loose. Repeat for other tow point.</p>	<p><b>TOOLS REQUIRED</b></p> <p>16/17mm socket/spanner 18/19mm socket/spanner</p>
	<p><b>FASTENERS</b></p> <p>4x M10x30 hex bolt 4x M10 heavy-duty washer 4x M12x30 hex bolt 4x M12 heavy-duty washer 2x M12 flange nut 2x M10 lollipop nutplate 2x dual nutplate</p>

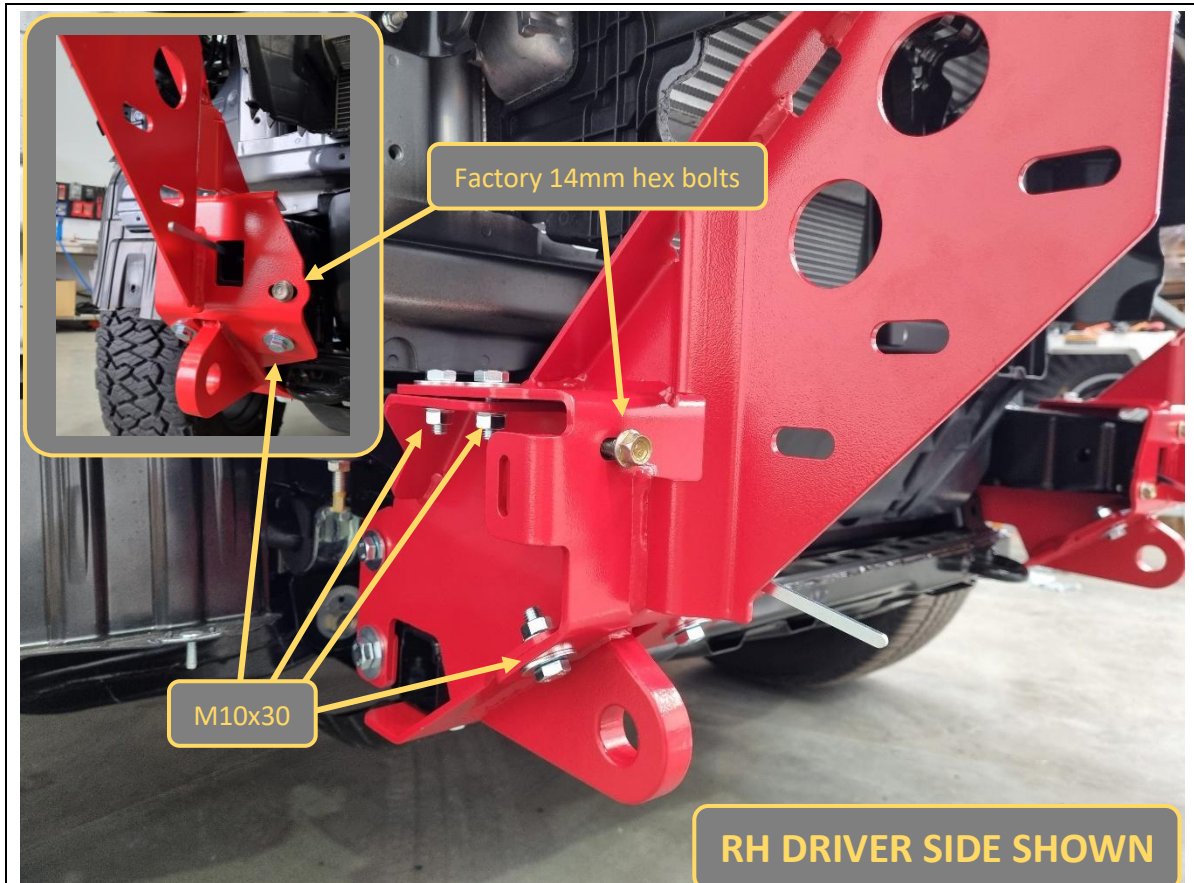

<p>64. Fit the impact assembly to the chassis and loosely secure using 2x factory 14mm hex bolts retained from the crash beam.</p> <p>65. Secure to the impact assembly to the tow point using 4x M10x30 hex bolts, heavy-duty washers and flange nuts as shown.</p> <p>66. Repeat for both sides of vehicle. Leave all bolts in the tow points and impact assemblies finger tight at this stage.</p>	<p><b>TOOLS REQUIRED</b></p> <p>14mm socket/spanner 16/17mm socket/spanner</p>
	<p><b>FASTENERS</b></p> <p>4x factory 14mm hex bolt 8x M10x30 hex bolt 8x M10 heavy-duty washer 8x M10 flange nut</p>

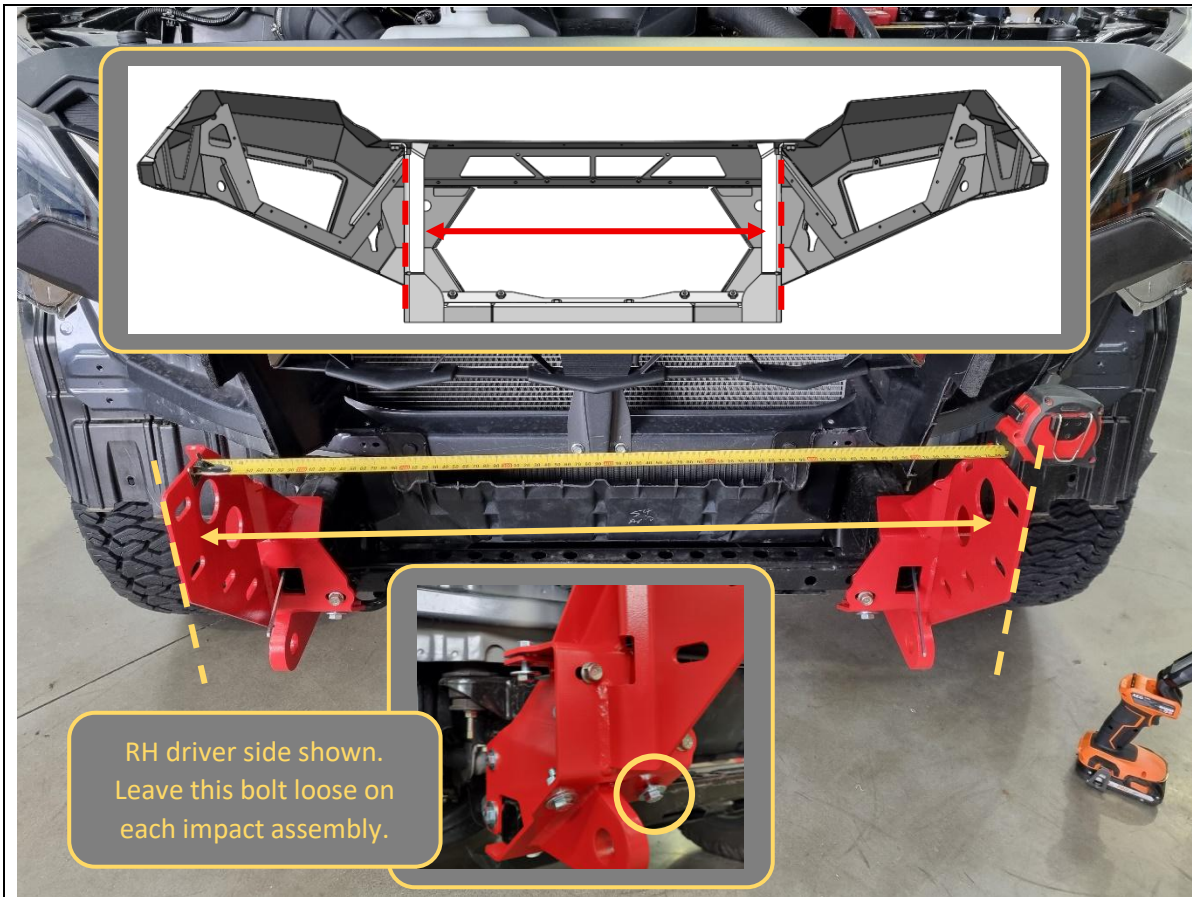

67. Measure the distance between the outside faces of uprights on bar using tape measure. Write distance below for reference if required.

Bar Upright Width = \_\_\_\_\_ mm

68. Adjust mounts by sliding left/right on the slots, such that distance between inner faces of mounts are 2-5mm more than bar. Ensure the mount faces are vertically upright and symmetric left/right on the chassis.

69. Tighten all bolts securing impact assemblies and tow points, except those highlighted (used later for attaching bash plates).

Tighten impact 14mm hex bolts first, then the side bolts for the tow points, bottom bolts for the tow points, and finally bolts connecting the impact assemblies to the tow points.

70. Re-check the distance and re-adjust as required.

**TOOLS REQUIRED**

Tape measure

14mm socket/spanner  
16/17mm socket/spanner  
18/19mm socket/spanner

**FASTENERS**

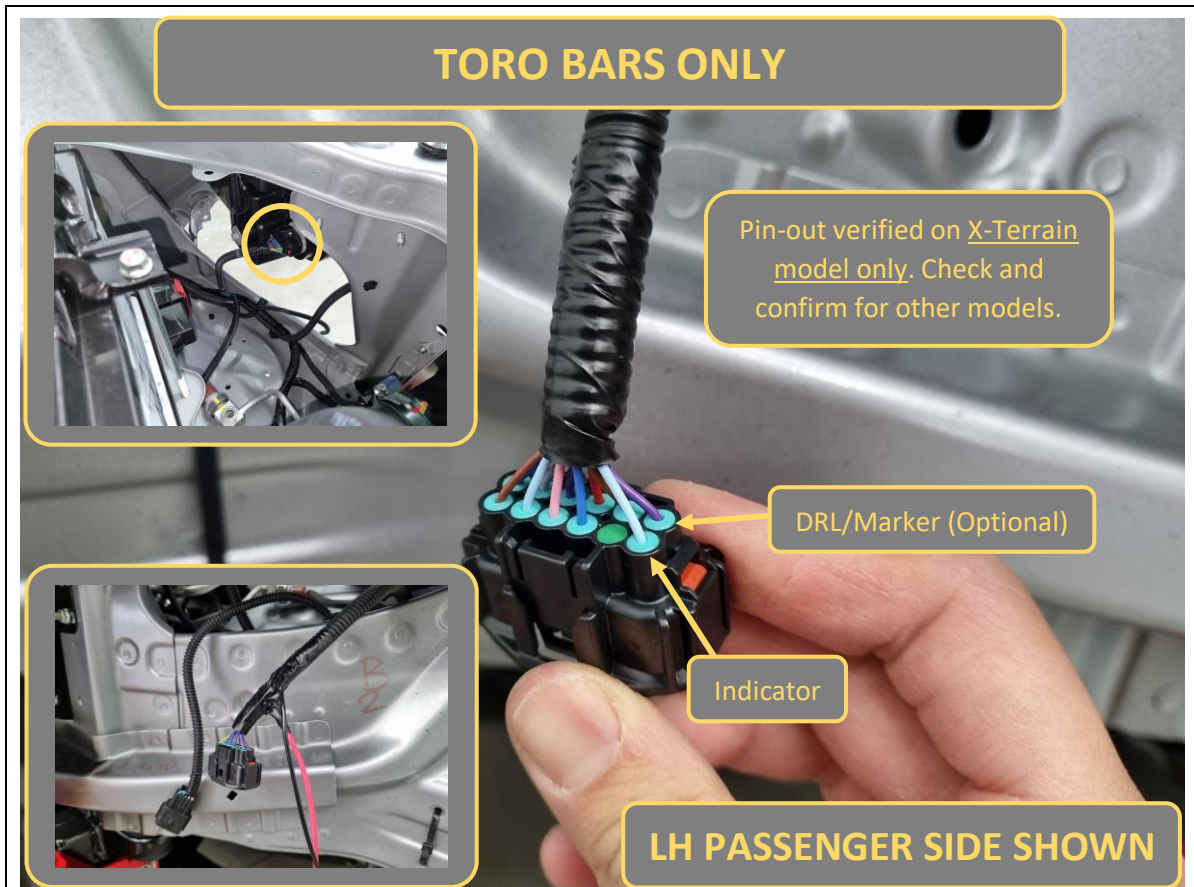

71. **Toro only.** Locate the plug for the indicator on the back of each headlight and disconnect.

72. **Toro only.** Probe with a test light to confirm indicator signal.

The supplied indicator units also have a DRL/parker light function built in. If desired, these may also be wired in. Also probe with a test light to confirm DRL/parker signal.

The above image shows the verified pin-out on an MY25 X-Terrain model. Check and confirm for other models.

The pin location on LH and RH headlight plugs are the same, but wire colours are different.

73. **Toro only.** Splice and solder automotive electrical wires into the harness for indicator signal. Use heat shrink or electrical tape to insulate solder connections. Do this for both LH and RH indicators, then re-plug back into headlight.

**TOOLS REQUIRED**

- Cutting pliers
- Wire strippers
- Soldering iron
- Solder
- Automotive electrical wire
- Heat shrink
- Heat gun
- Electrical tape

**FASTENERS**



74. Fit 10x M6 cage nuts into the rectangular slots in bottom of bull bar wing (5x per side).

Use a small flat blade screwdriver to push the edge of the cage to engage with the slot to aid fitting.

**TOOLS REQUIRED**

Flat blade screwdriver

**FASTENERS**

10x M6 cage nut

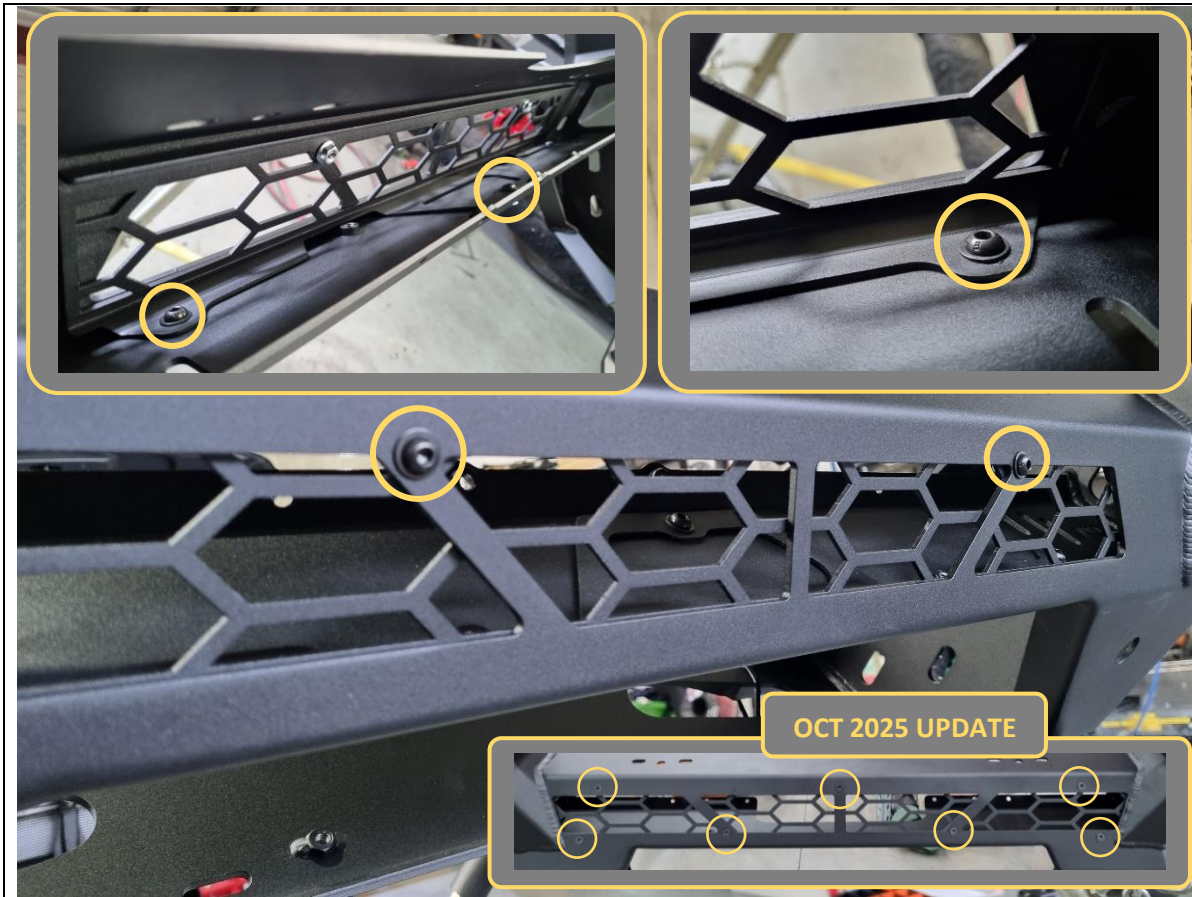

75. Fit the B-1485 mesh infill to the inside of the centre section of the bull bar. Please note fitment is tight and infill will need to be pivoted to fit into bar.

**Note:** Fitment of this part is required on all bars.

76. Secure infill with 5x M6x12 black button head bolts, black flat washers and flange nuts. For the bottom 3x bolts, have the bolt head facing upwards for better visual appearance.

**OCT 2025 UPDATE**

B-1485 will be replaced by P-0515. Fit infill to inside of bar, and secure to the front face with 7x M6x12 black countersunk bolts and flange nuts.

**TOOLS REQUIRED**

4mm hex/Allen key

**FASTENERS**

5x M6x12 black button head bolt  
5x M6 black flat washer  
5x M6 flange nut

**OCT 2025 UPDATE**

7x M6x12 black countersunk bolt  
7x M6 flange nut



77. If fitting an integrated light bar, do so now.

This bar is designed to fit the Offroad Animal 22-inch light bar. If fitting this light bar, assemble the light bar with legs facing outwards, and line it up with the slots in the centre gusset. Secure with M6 fasteners supplied with the light.

This bar can accommodate most other “20-22inch” size single row light bars. Stedi ST3K light bars require legs facing inwards.

78. If fitting driving lights to this bar, this is also the most convenient time to do so. It is still possible later, but it is more difficult.

The Predator bar supports up to 9” round driving lights.

The Toro bar supports up to 9” round driving lights, but only ones with a slim back like the Offroad Animal Asskicker lights. Otherwise 8.5” Stedi Type X Evo is the maximum size.

**TOOLS REQUIRED**

Supplied with accessories

**FASTENERS**

Supplied with accessories



<p>79. <b>Toro only.</b> Fit indicator units to the bar, using fasteners supplied with the indicator.</p>	<p><b>TOOLS REQUIRED</b></p> <p>8mm socket/spanner</p>
	<p><b>FASTENERS</b></p> <p>Supplied with indicators</p>



<p>80. <b>Toro only.</b> Fit the M-0065 wing light meshes to the inside of each bull bar wing and secure with 2x M6x16 black button head bolts and black flat washers.</p> <p>Leave the bottom inner hole empty now, this is used for fog light fitment.</p>	<p><b>TOOLS REQUIRED</b></p> <p>4mm hex/Allen key</p>
	<p><b>FASTENERS</b></p> <p>4x M6x16 black button head bolt 4x M6 black flat washer</p>

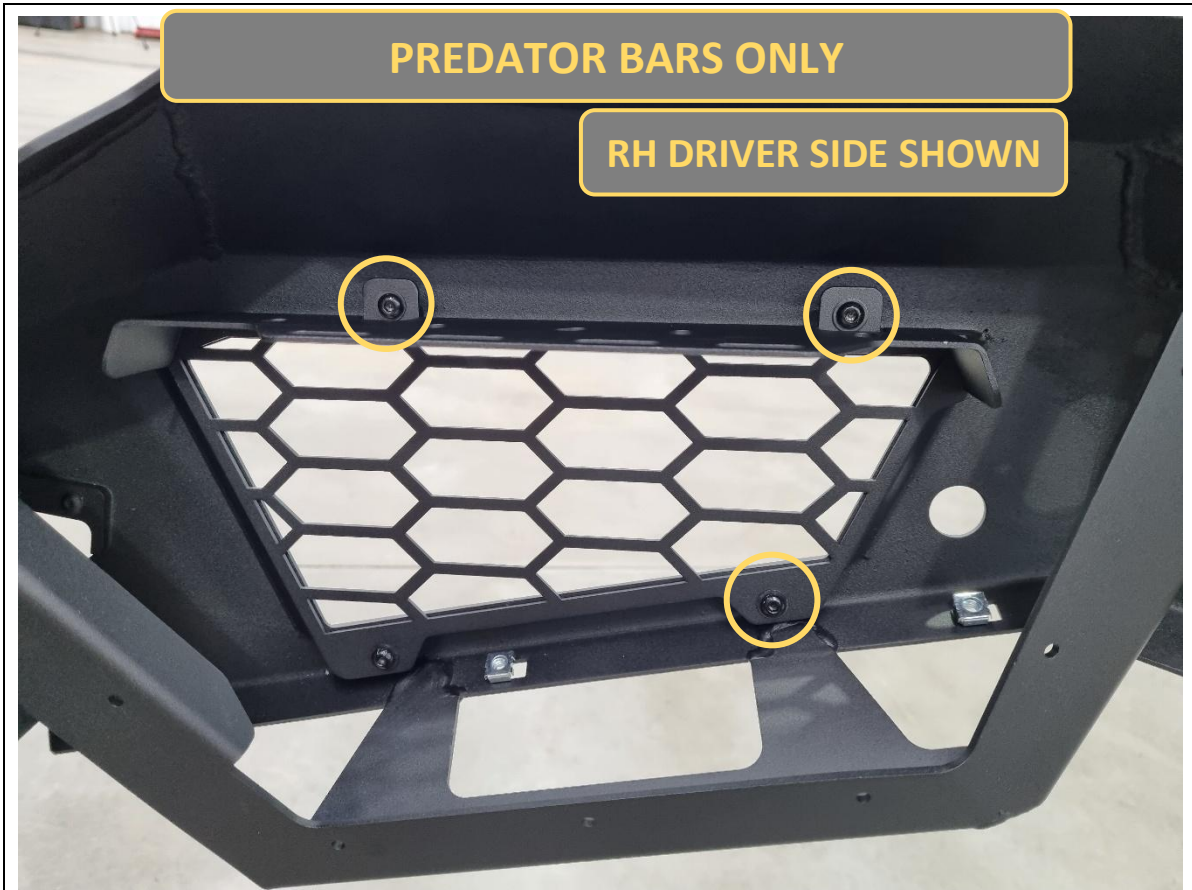

<p>81. <b>Predator only.</b> Fit the M-0064 wing light meshes to the inside of each bull bar wing and secure with 3x M6x16 black button head bolts and black flat washers.</p> <p>Leave the bottom inner hole empty now, this is used for fog light fitment.</p>	<p><b>TOOLS REQUIRED</b></p> <p>4mm hex/Allen key</p>
	<p><b>FASTENERS</b></p> <p>6x M6x16 black button head bolt 6x M6 black flat washer</p>



<p>82. If equipped, unplug each fog light from the loom and then fit to the supplied mounting bracket and secure with 4x M6x16 black button head bolts, black washers and flange nuts.</p>	<p><b>TOOLS REQUIRED</b></p> <p>4mm hex/Allen key</p>
	<p><b>FASTENERS</b></p> <p>8x M6x16 black button head bolt 8x M6 black flat washer 8x M6 flange nut</p>

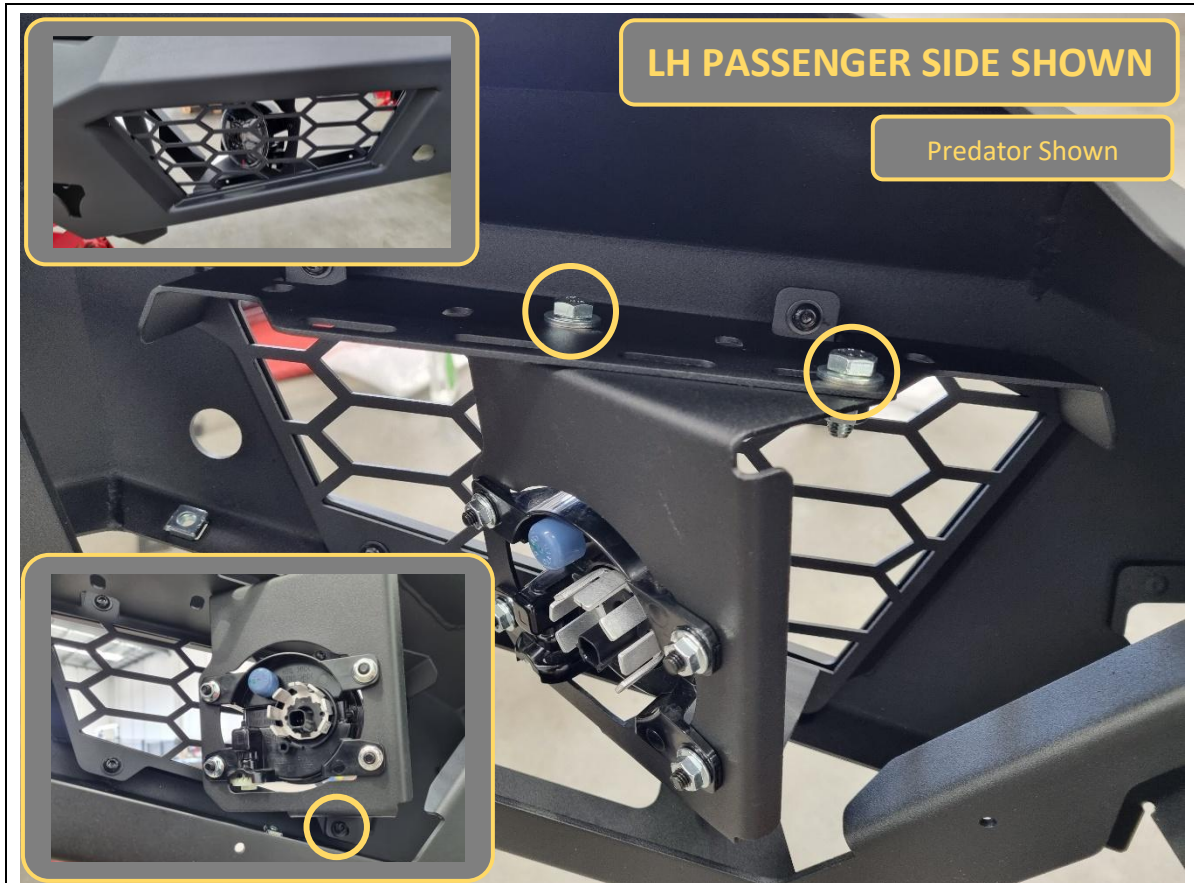

83. If equipped, fit the fog light and mounting bracket to the inside of the bullbar wing.
84. Secure the top with 2x M8x20 hex bolts, flat washers and flange nuts.
85. Secure the bottom through the remaining empty hole in the wing mesh with 1x M6x16 black button head bolt and black washer.
86. Repeat for other side.

**TOOLS REQUIRED**

13mm socket/spanner  
4mm hex/Allen key

**FASTENERS**

4x M8x20 hex bolt  
4x M8 flat washer  
4x M8 flange nut  
  
2x M6x16 black button head  
2x M6 black flat washer



**PREDATOR BARS ONLY**

**RH DRIVER SIDE SHOWN**

<p>The wing meshes support some other different lighting options. Refer to the next few pages for mounting various lights.</p> <p>87. <b>Predator only.</b> If fitting 8" light bars, bolt them to the underside of the wing mesh flange using fasteners supplied with the light. <u>Also fit the missing M6x16 black button head bolt and black washer in the remaining hole in the wing mesh.</u></p>	<p><b>TOOLS REQUIRED</b></p> <p>Supplied with accessories</p> <p>4mm hex/Allen key</p>
	<p><b>FASTENERS</b></p> <p>Supplied with accessories</p> <p>2x M6x16 black button head 2x M6 black flat washer</p>



<p>88. If fitting cube lights, up to 2x can be fitted to each wing mesh for the Predator bar. Toro bars can only take 1x per wing.</p> <p>89. Bolt them to the underside of the wing mesh flange using fasteners supplied with the lights.</p> <p><b>Note:</b> For Stedi C4 lights (not pictured), spacers are needed to shift the light downwards so they align with the opening in the bull bar. Offroad Animal brand cube lights (pictured) do not need spacers.</p>	<p><b>TOOLS REQUIRED</b></p> <p>Supplied with accessories</p> <p>4mm hex/Allen key</p>
<p>90. Also fit the missing M6x16 black button head bolt and black washer in the remaining hole in the wing mesh.</p>	<p><b>FASTENERS</b></p> <p>Supplied with accessories</p> <p>2x M6x16 black button head 2x M6 black flat washer</p>



91. Route the bumper wiring harness through the inside of the bullbar.

Use the provided cutouts to route parking sensors to the round holes in the bullbar.

If required, temporarily disconnect sensors to route through.

Ensure the harness is orientated correctly, with the plug connecting to the vehicle on the LH side.

92. Re-connect the fog lights.

**TOOLS REQUIRED**

**FASTENERS**

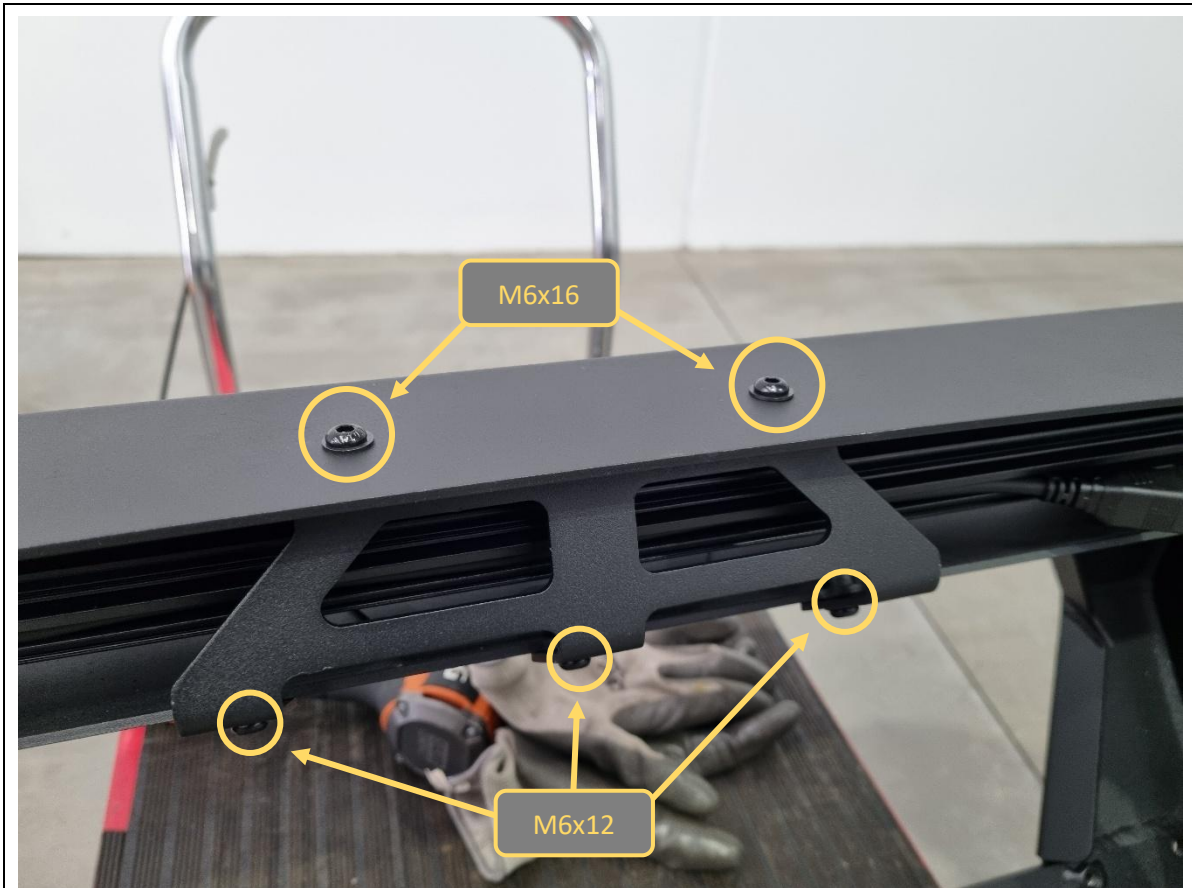

<p>93. Fit the pan brace bracket to the back of the centre section of the bull bar.</p> <p>94. Secure at the top with 2x M6x16 black button head bolts, black washers and flange nuts.</p> <p>95. Secure the bottom to the embedded nuts in the bull bar with 3x M6x12 black button head bolts and black washers.</p>	<p><b>TOOLS REQUIRED</b></p> <p>4mm hex/Allen key</p>
	<p><b>FASTENERS</b></p> <p>3x M6x12 black button head 2x M6x16 black button head 5x M6 black flat washer 2x M6 flange nut</p>



<p>96. <b>Predator only.</b> If fitting top tubes (Stealth Hoop, Round Hoop or Rally Hoop) to the Predator bar, now is the best time to do so. It is still possible later, but it is more difficult.</p> <p>The Stealth Hoop and Rally Hoop come with provisions to relocate the front 360 degree camera. The camera relocation kit (TB-COM-ISU-CAM-BRKIT) is purchased separately. Refer to next few steps for how to do that. <u>It is recommended to do this before the top tube is bolted to the bar.</u></p>	<p><b>TOOLS REQUIRED</b></p> <p>Supplied with accessories</p>
	<p><b>FASTENERS</b></p> <p>Supplied with accessories</p>



97. **Predator only (optional).** If relocating the front camera, remove 3x small Phillips head screws holding the camera to its mounting bracket. Retain these screws.

**TOOLS REQUIRED**  
Small Phillips head screwdriver

**FASTENERS**  
3x Phillips head screws  
Retain



98. **Predator only (optional).** Fit the camera to the relocation bracket in the optional camera relocation kit using the original small Phillips head screws.

**TOOLS REQUIRED**

Small Phillips head screwdriver

**FASTENERS**

3x Phillips head screws



99. **Predator only (optional).** Fit the camera and relocation bracket to the inside of the camera housing.
100. **Predator only (optional).** Next fit the camera assembly to the holes in the underside of the Stealth Hoop or Rally Hoop, and secure with 2x M6x16 black button head bolts, black washers and flange nuts.

Camera relocation is now complete. Remember to plug the camera back into the vehicle harness once the bar is fitted.

**TOOLS REQUIRED**

4mm hex/Allen key

**FASTENERS**

2x M6x16 black button head bolt  
2x M6 black flat washer  
2x M6 flange nut



<p>101. If equipped, the plastic parking sensor holders need to be modified to be able to clip them into the bullbar.</p> <p>102. Disconnect the parking sensor with holder attached from the loom. Take care not to mix the location of each sensor on the harness.</p>	<p><b>TOOLS REQUIRED</b></p> <p>Utility knife</p>
<p>103. Using a utility knife, trim 2mm off the front of the push in tabs (up to the join in the middle as shown).</p> <p>104. Do for all 4 tabs around each sensor holder.</p> <p>105. Also shave off the vertical keying feature on each sensor holder so that it is flush with the main cylindrical barrel of the sensor holder.</p> <p>106. Separate the parking sensors and sensor holders, then re-fit parking sensors back to the harness in the bar in their correct positions.</p>	<p><b>FASTENERS</b></p>

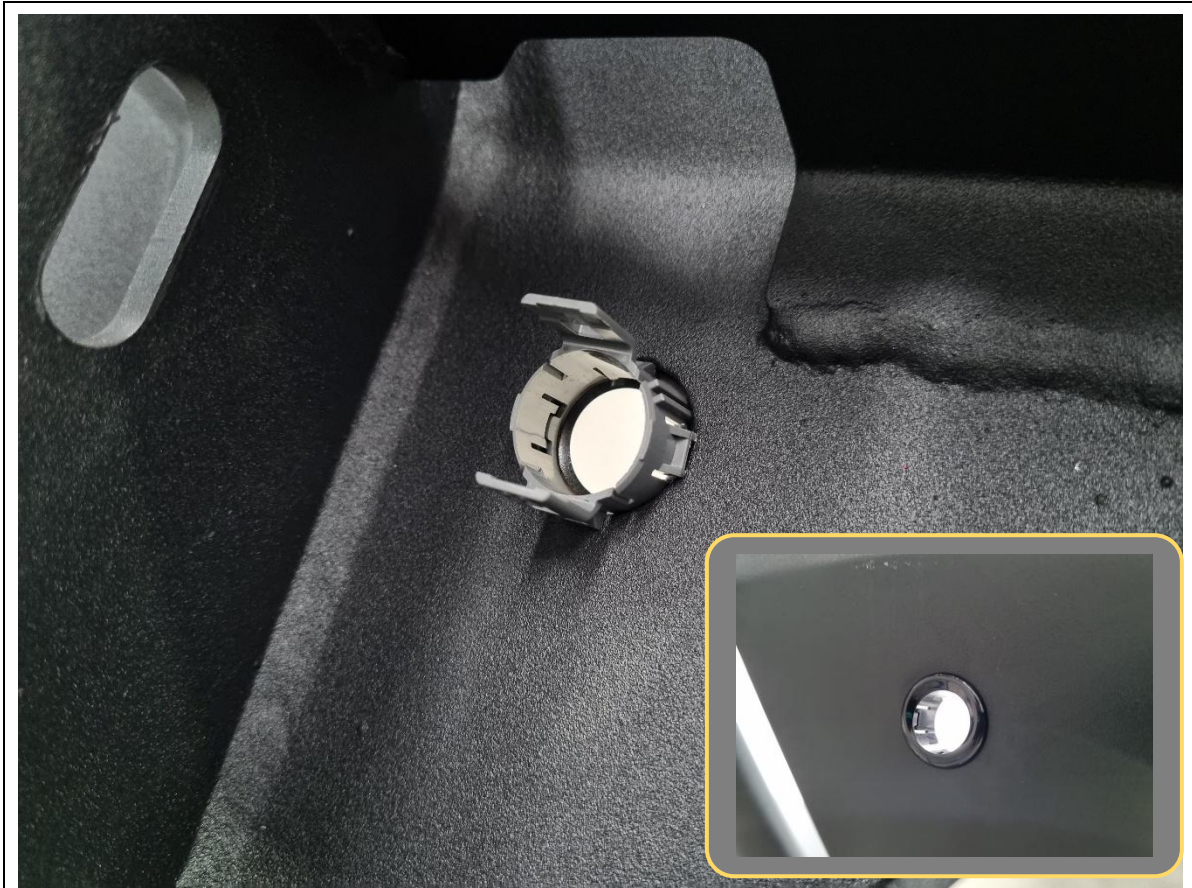

107. Clip in the parking sensor holders in the bar in their correct positions and orientations. Ensure the tabs are engaged and locked in.

If the sensor holder is loose and is rotating in the bar, apply a small blob of Sikaflex silicone adhesive to fix its position.

**TOOLS REQUIRED**

Sikaflex (optional)

**FASTENERS**



<p>108. Fit the parking sensors back into each sensor holder, with the plugs facing the correct direction.</p> <p><b>Note:</b> Leave the middle 2x sensors slightly loose, as these may need to be temporarily removed for tool access while securing the bar onto the car.</p>	<p><b>TOOLS REQUIRED</b></p> <p>Cable ties</p>
<p>109. Once the bumper loom is all in position, use cable ties to secure and tidy it up inside the bull bar.</p>	<p><b>FASTENERS</b></p>



<p>110. If parking sensors are not equipped, insert the supplied plastic round blanking plugs into all 4x parking sensor holes in the bullbar (see inset photos). It is recommended to use some Sikaflex silicone adhesive to ensure the plugs do not all out.</p>	<p><b>TOOLS REQUIRED</b></p> <p>Sikaflex (optional)</p>
	<p><b>FASTENERS</b></p>



111. Fit the supplied lengths of pinch weld rubber to the top edge of the wing on each side of the bullbar.

Trim to length if required.

**TOOLS REQUIRED**

Side cutters

**FASTENERS**

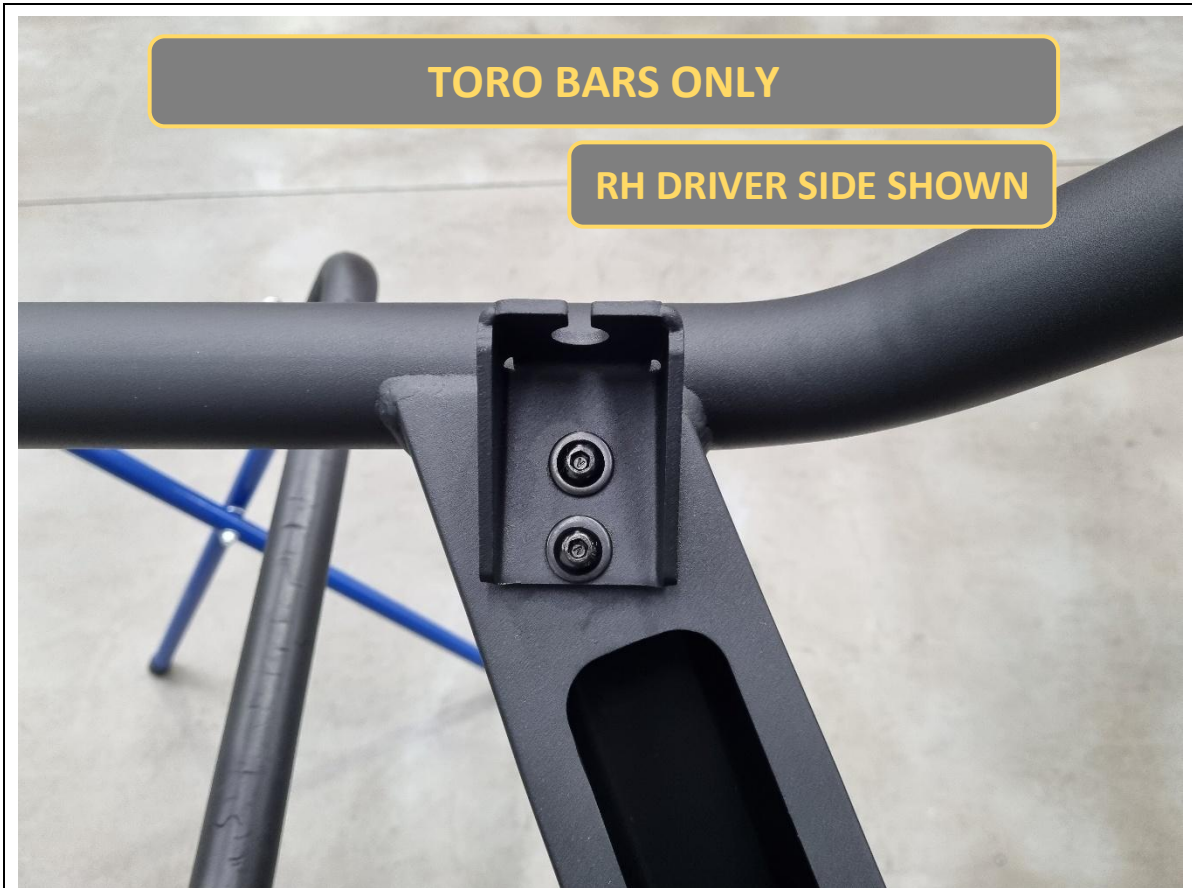

<p>112. <b>Toro only.</b> If required, fit the supplied antenna mounting brackets to the back of the bar, and secure with 2x M8x20 black button head bolts and black washers, each.</p> <p>113. <b>Toro only.</b> Else fit the 2x M8x20 black button head bolts and black washers to the back of each bullbar upright, to protect nut threads in bar for future use.</p>	<p><b>TOOLS REQUIRED</b></p> <p>5mm hex/Allen key</p>
	<p><b>FASTENERS</b></p> <p>4x M8x20 black button head bolt 4x M8 black flat washer</p>



114. The bull bar is now finally ready to go onto the vehicle. With assistance, either from another person or a lifting trolley, lift the bar onto the mounts on the vehicle.

**TOOLS REQUIRED**

Lifting trolley

**FASTENERS**



115. Secure the bar to the mounts with 8x M12x30 bolts, heavy-duty washers and Nyloc + flange nuts. Leave finger tight at this stage.

**Note:** Use a washer on both bolt and nut side for the Nyloc nut. 1x Nyloc required per side of the bar. 1x washer on the bolt side is all that is required with flange nuts.

**TOOLS REQUIRED**

18/19mm socket/spanner

**FASTENERS**

8x M12x30 hex bolt  
10x M12 heavy duty washer  
2x M12 Nyloc nut  
6x M12 flange nut

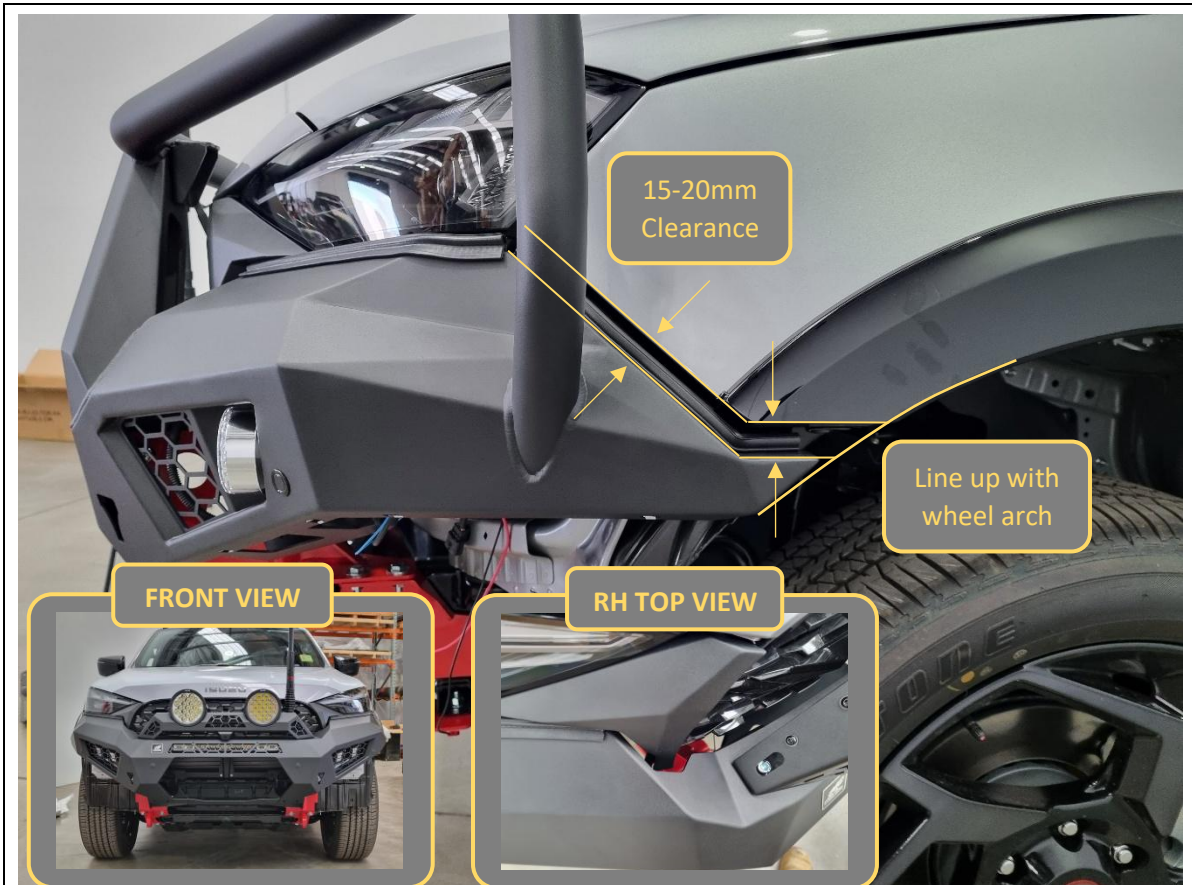

116. With assistance, from another person, align the bar with the edges of the vehicle. Adjust such that the clearances are neat, and the bar is symmetric left/right on the vehicle.

Acceptable range of clearances are outlined below.  
**Ensure clearances are maintained all the way below the headlight.**

**Front view:** The bar should sit horizontally level. The top edge of the wings should be 10-15mm below the bottom of the headlight/grille infill.

**Side view:** The bar should have 15-20mm vertical clearance to the quarter panel. The end of the bar wing should be in line with the wheel arch liner. The top edge of the wing should be 5-10mm in front of the headlight.

**Top view:** There should be around 15mm clearance between the bar and the grille.

117. Once happy with alignment, fully tighten all 8x M12 bolts.

**TOOLS REQUIRED**

- Lifting Trolley
- 18/19mm socket/spanner

**FASTENERS**

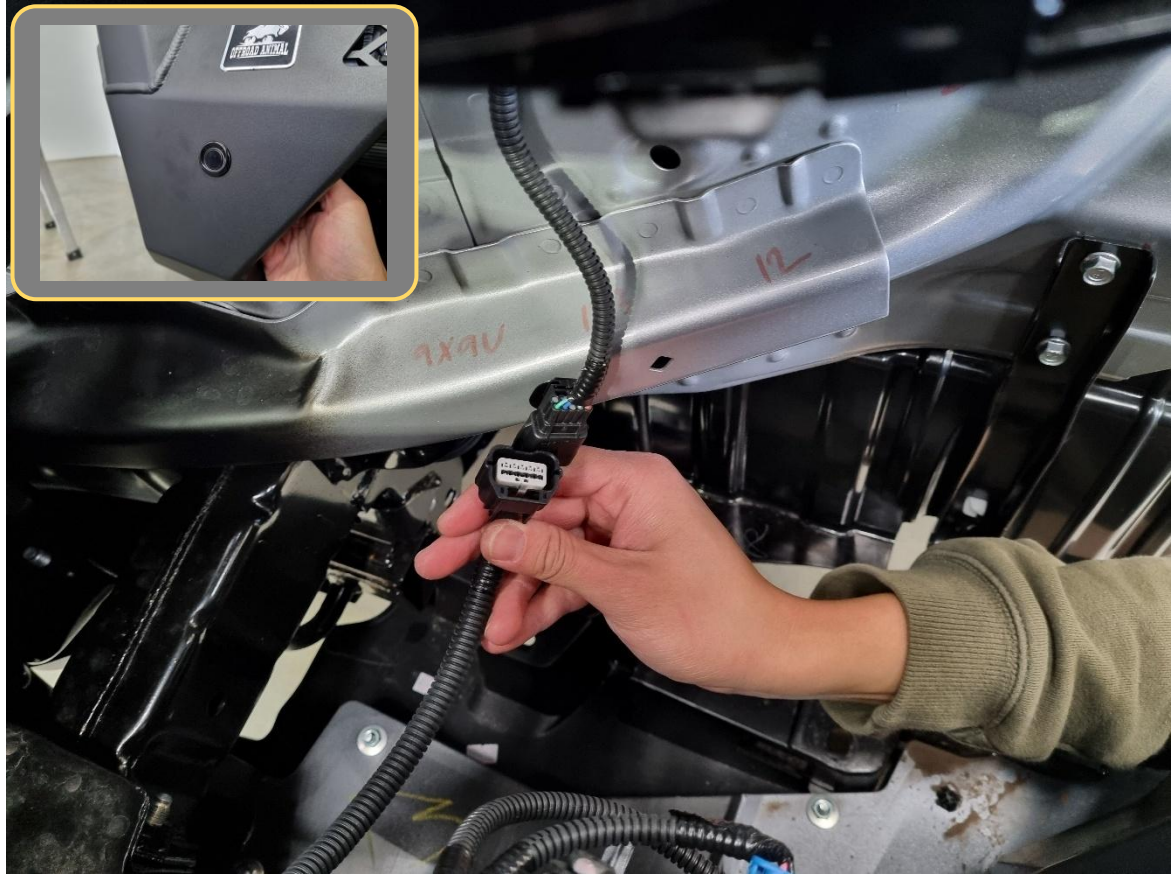

118. Re-connect the bumper harness back to the vehicle.

**Predator only.** Remember to plug in the camera if relocating to the top hoop.

119. Also clip in the middle 2x parking sensors after the mounting bolts are tightened.

**TOOLS REQUIRED**

**FASTENERS**



- 120. **Toro only.** Connect the indicator repeater lamps to the vehicle headlight harness (solder/crimp together, ensure well insulated). Refer to packaging on indicator lamps for pinout.
- 121. **Toro only.** Ground each indicator repeater lamp to the M6 bolt on the upper cross member (see bottom inset photo).
- 122. Check all wiring is connected, and that fog lights, indicators (Toro only) and parking sensors are all functional.

**TOOLS REQUIRED**

10mm socket/spanner

**FASTENERS**

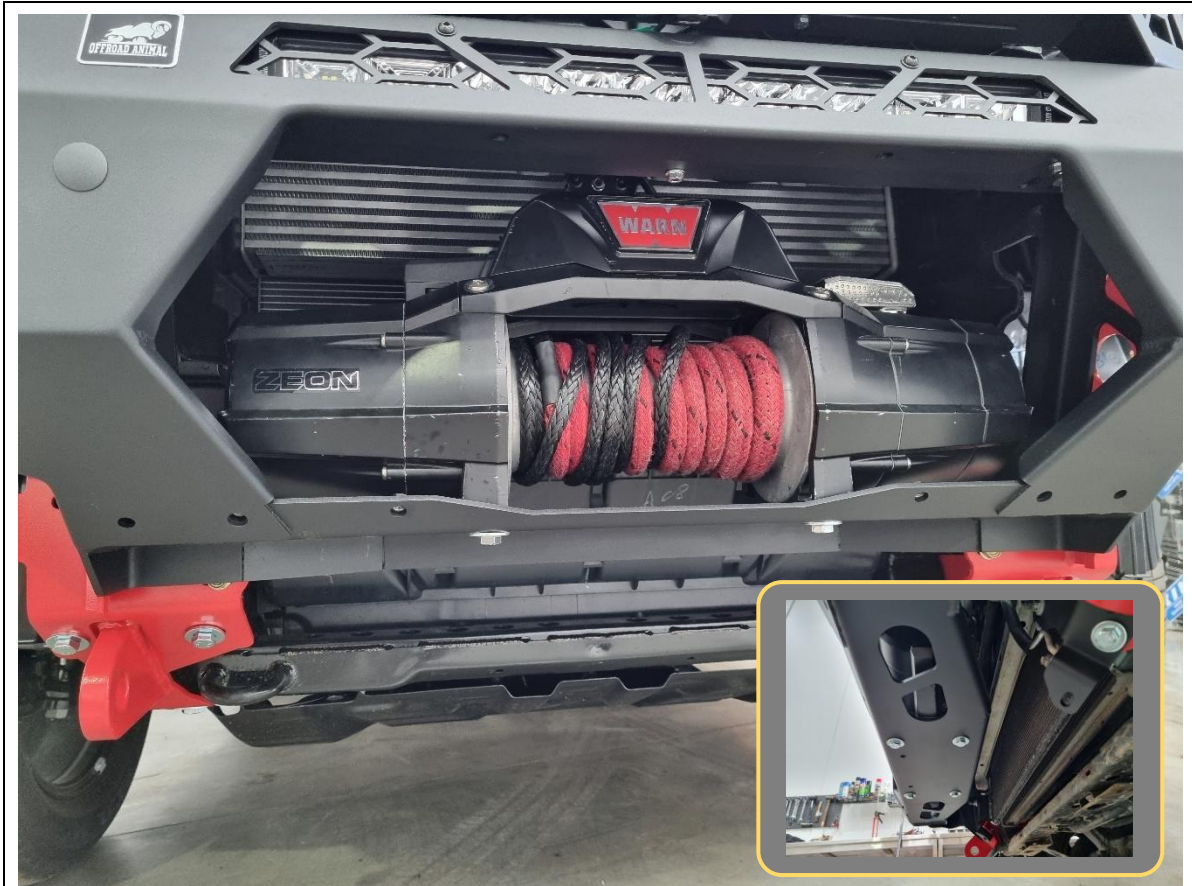

123. If fitting a winch, do so now. Lift the winch into the opening at the front of the bull bar.

This bar is designed to fit most low mount winches, in foot down configuration. Secure the winch with bolts underneath the cradle.

WARN ZEON 12 is the largest winch confirmed to fit.

Ensure clutch handle will be accessible through opening in front mesh panel. Refer to winch instructions regarding changing clutch handle location.

**TOOLS REQUIRED**

Refer to instructions supplied by winch

**FASTENERS**

Supplied with winch

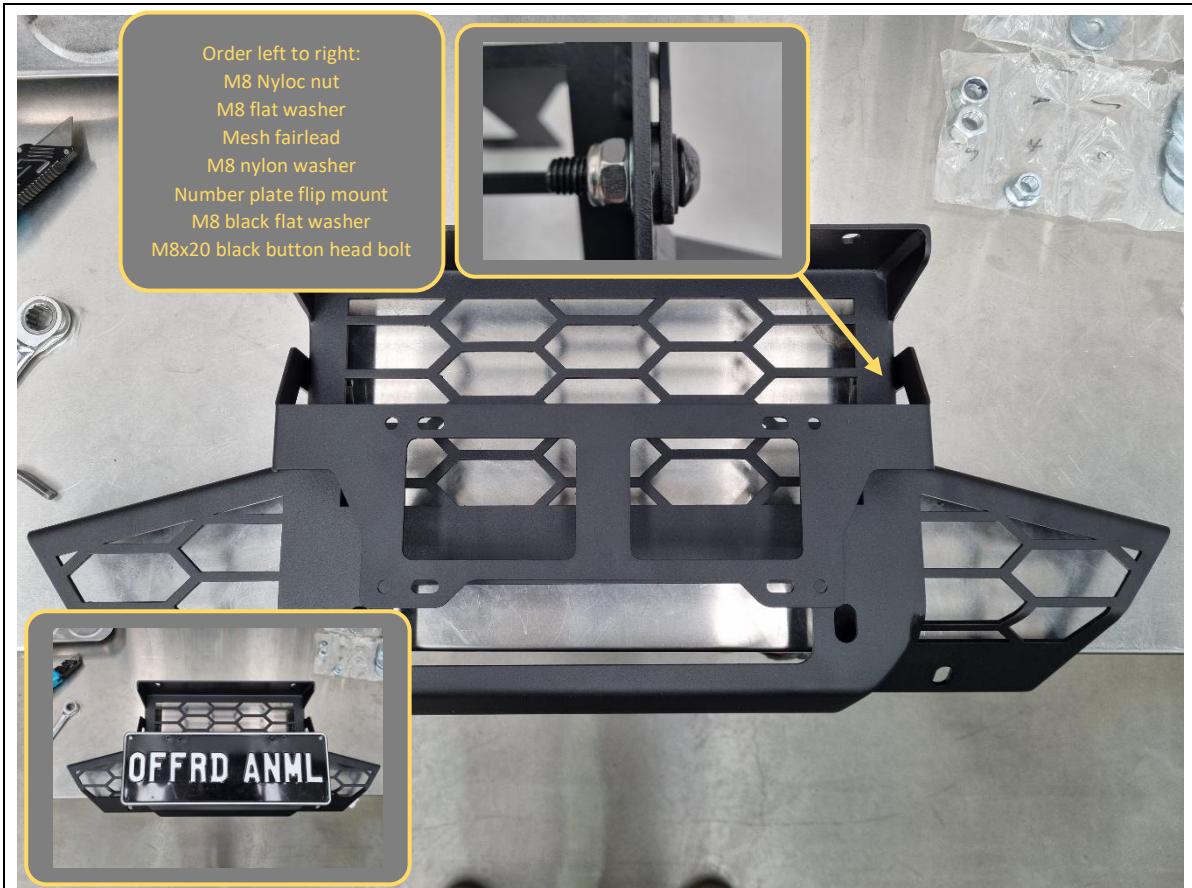

- 124. Fit number plate flip mount to mesh panel as shown above. Tighten bolts so that flip mount can be moved by hand with some friction resistance.
- 125. Attach number plate to mount using 2x M6x16 black button head bolts, black washers and flange nuts.

**TOOLS REQUIRED**

- 5mm hex/Allen key
- 13mm socket/spanner
- 4mm hex/Allen key

**FASTENERS**

- 2x M8x20 black button head
- 2x M8 black flat washer
- 2x M8 nylon washer
- 2x M8 flat washer
- 2x M8 flange nut
- 2x M6x16 black button head bolts
- 2x M6 black flat washer
- 2x M6 flange nut



<p>126. If required, fit the winch fairlead to the mesh fairlead mount using M10 or 3/8" fasteners supplied with the winch. This bar is only compatible with hawse type fairleads.</p>	<p><b>TOOLS REQUIRED</b></p> <p>Refer to instructions supplied by winch</p>
	<p><b>FASTENERS</b></p> <p>Supplied with winch</p>



- 127. Present the centre mesh up to the centre opening of the bar. If a winch is fitted, feed the winch rope through the hawse fairlead and fit the winch hook.
- 128. Secure the centre mesh to the bar using 2x M8x16 black button head bolts + black washers (top), 2x M8x20 hex head bolts + flat washers (bottom).

**TOOLS REQUIRED**

13mm socket/spanner  
5mm hex/Allen key

**FASTENERS**

2x M8x16 black button head  
2x M8 black flat washer

2x M8x20 hex head  
2x M8 flat washer



- 129. Temporarily remove the 2x M10x30 hex bolts from the impact assemblies in preparation for fitting the bash plate. Set them aside.
- 130. Fit the centre bash plate and secure the top to the bullbar using 4x M8x30 black button head bolts and black washers.

**TOOLS REQUIRED**

5mm hex/Allen key  
16/17mm socket/spanner

**FASTENERS**

4x M8x30 black button head bolt  
4x M8 black flat washer

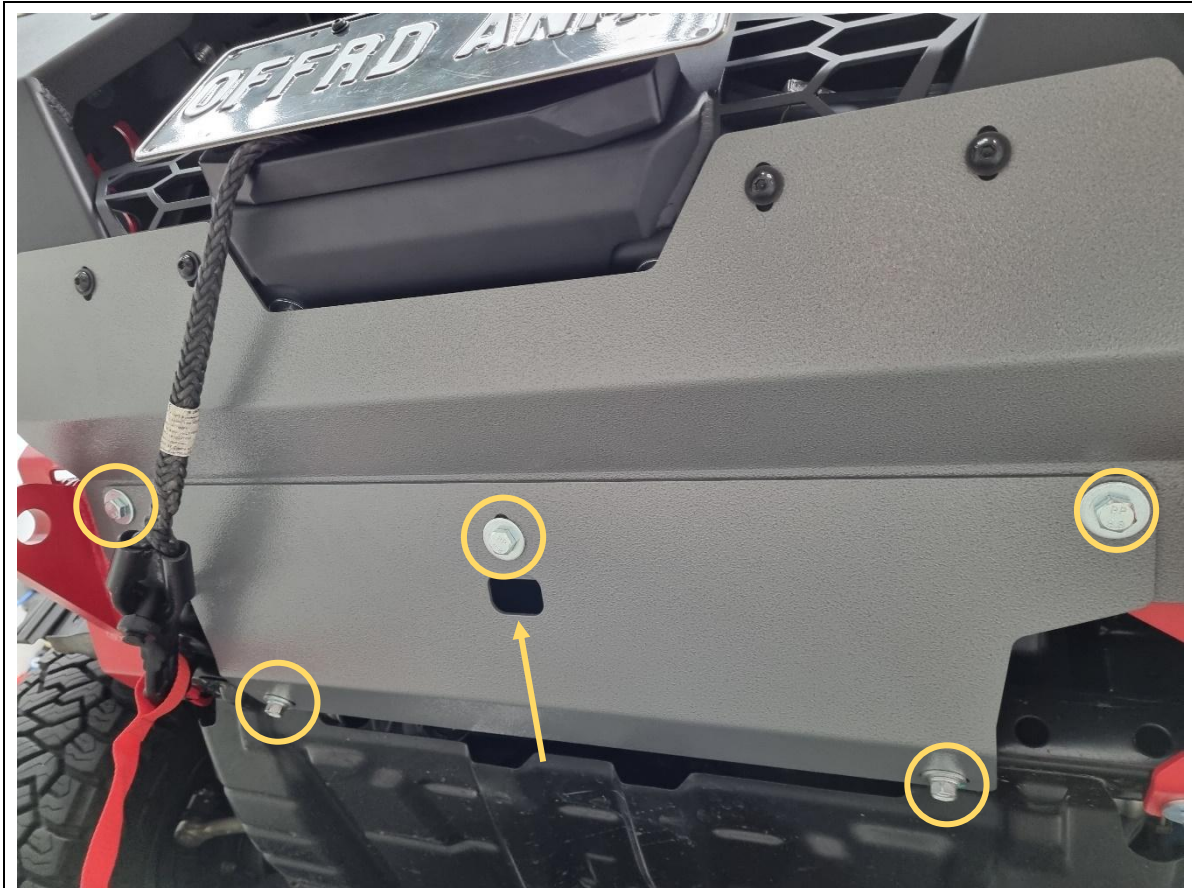

<p>131. Fit the supplementary lower bash plate and secure the rear through the factory underbody plate and into the chassis using the 2x factory 14mm hex bolts removed earlier.</p> <p>132. Secure the front of the supplementary bash plate to the centre bash plate/impact assemblies/tow points with 3x M10x30 hex bolts, heavy duty washers and flange nuts.</p>	<p><b>TOOLS REQUIRED</b></p> <p>14mm socket/spanner 16/17mm socket/spanner</p>
<p>Reach through the small access hole in the supplementary bash plate (see arrow) to reach middle flange nut.</p>	<p><b>FASTENERS</b></p> <p>2x factory 14mm hex bolt 3x M10x30 hex bolt 3x M10 heavy duty washer 3x M10 flange nut</p>



<p>133. Peel off the backing film and affix the ADR compliance plate to the inside of RH side underpanel.</p> <p>134. Fit the side underpanels to the underside of the bull bar wings, then loosely secure to the M6 cage nuts in the bullbar with 5x M6x16 black button head bolts and black washers, each.</p>	<p><b>TOOLS REQUIRED</b></p> <p>4mm hex/Allen key 5mm hex/Allen key</p>
<p>135. Loosely secure the bottom inside corner of side underpanels to the impact assemblies using the 1x M8x20 black button head bolt, black washer and flange nuts, each.</p>	<p><b>FASTENERS</b></p> <p>10x M6x16 black button head 10x M6 black flat washer</p> <p>2x M8x20 black button head 2x M8 black flat washer 2x M8 flange nut</p>



**RH DRIVER SIDE SHOWN**

<p>136. Apply masking tape to the wheel arch liner, then mark out a cut line that matches the profile of the side underpanel.</p> <p>137. Remove the side underpanels.</p> <p>138. Cut the wheel arch liners along the marked lines using a utility knife or similar cutting tool.</p> <p>Whilst cutting, pull down on the section to be removed and apply tension, to allow for an easy cut.</p>	<p><b>TOOLS REQUIRED</b></p> <p>4mm hex/Allen key 5mm hex/Allen key</p> <p>Masking tape Marker pen Utility knife Deburring tool</p>
<p>139. Clean up the cut edge with a deburring tool or similar.</p>	<p><b>FASTENERS</b></p>



140. **Optional.** Drill a hole through the inner wheel arch liner and use a cable tie to secure it to the body, as shown.

**TOOLS REQUIRED**

Electric drill  
Cable tie

**FASTENERS**



- 141. Re-fit the side underpanels and tuck the wheel arch liner in behind the flange.
- 142. Tighten all side underpanel bolts and repeat for other side.
- 143. The fitment is now complete. Double check all fasteners are done up.

**TOOLS REQUIRED**

- 4mm hex/Allen key
- 5mm hex/Allen key

**FASTENERS**

- 10x M6x16 black button head
- 10x M6 black flat washer
- 2x M8x20 black button head
- 2x M8 black flat washer
- 2x M8 flange nut



**Congratulations! You're done! Go touring in your good looking and tough MU-X!**